



Office of Exceptional Student Education

Fisher Building • 3011 West Grand Blvd. • Detroit, MI 48202

O (313) 873-7740

[detroitk12.org](http://detroitk12.org)

*Office of Exceptional Student Education*

# Distance Learning Packet

Early Childhood

Special Education

Weeks 1-9: April 14 – June 12, 2020



Students Rise. We all Rise

DPSCD does not discriminate based on race, color, national origin, sex, disability and/or religion

Contact Compliance for more information at (313) 240-4377 or [detroitk12.org/admin/compliance](http://detroitk12.org/admin/compliance).

---

# Early Childhood Special Education

WEEKLY DISTANCE LEARNING STUDENT SCHEDULE

---



## Weeks of 4/13/20 to 6/12/20

Directions: Children should complete 1 -2 assignments per week. Each assignment can be extended by using things in the home to help with the lesson.

Suggestions for extensions to the assignments:

1. After a lesson on a letter, have children locate that letter on labels in the home.
2. When learning colors, Play “Eye Spy” around the house. Say the color for the week is red, then you look around the house or place something around the house that is red and say “Eye Spy with my little eye something red” and have the child look for it.
3. Read to your child daily. Have them point to pictures, repeat words, repeat sounds, try to guess what is going to happen in the story. Ask who, what, when, where questions. You can also have celebrities read to your child online at [www.storylineonline.net](http://www.storylineonline.net)
4. Have the children play the matching game with homemade number, letter or color cards.
5. For Science you can go for a walk outside and talk about the trees, flowers, insects, bugs, and the temperature.
6. Extend the rhyming lesson by finding things around the house that rhyme.
7. Extend the lesson on shapes by having children see the shapes of items around the house.
8. Extend writing by having children use house flour on a cookie sheet and make their lines. Or provide them with paper and pretend you are ordering food at restaurant and let them squiggle write. Your order down. Then, have them tell you what they wrote.



# Back to School

## Tracing Numbers

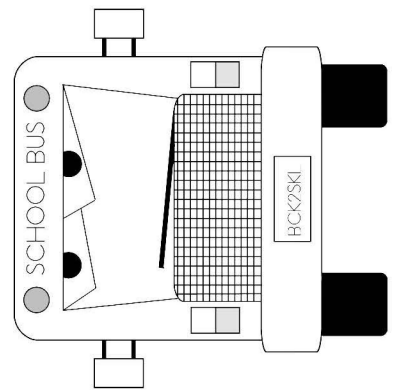
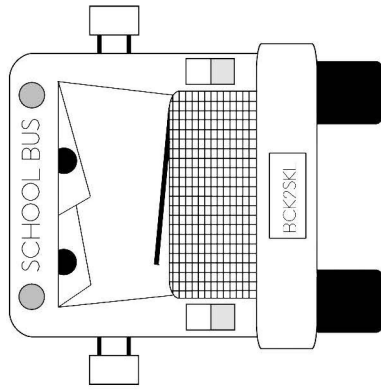
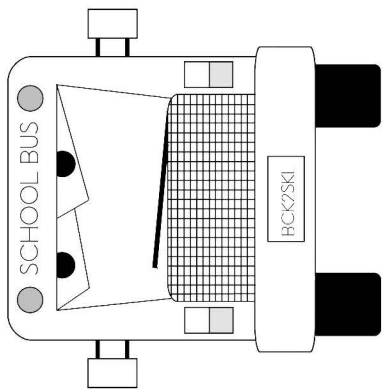
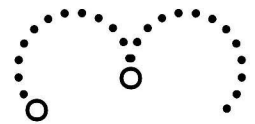
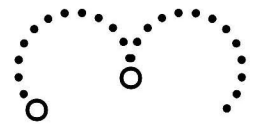
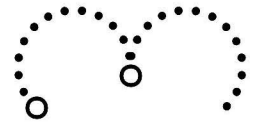
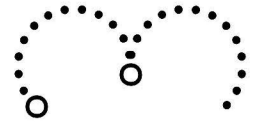
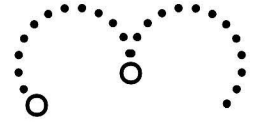
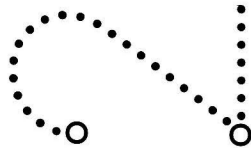
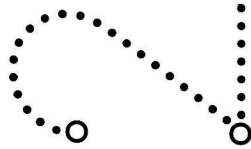
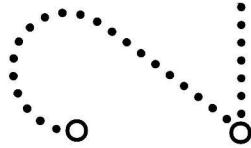
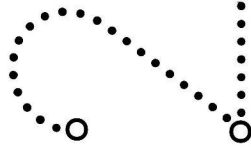
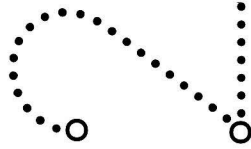
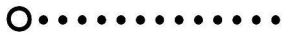
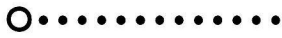



# Back to School

## Tracing Numbers

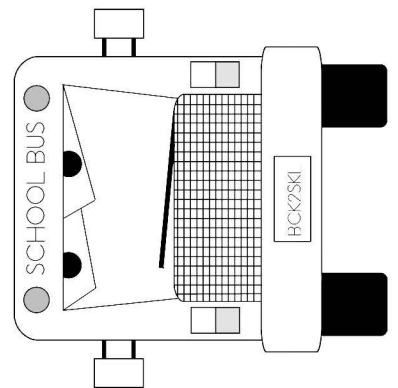
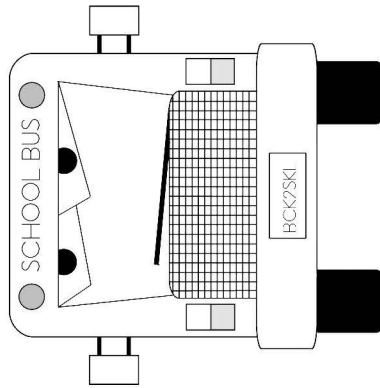
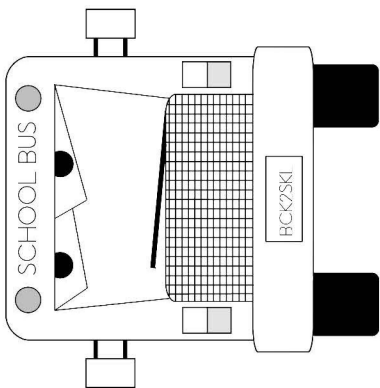
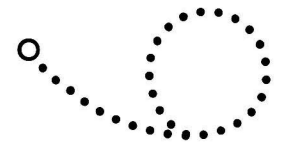
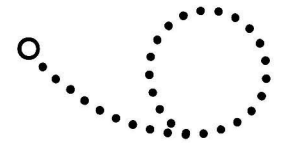
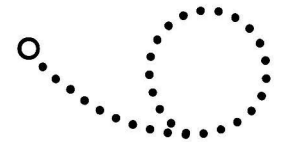
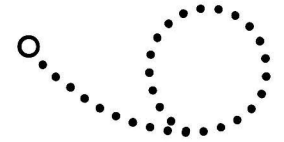
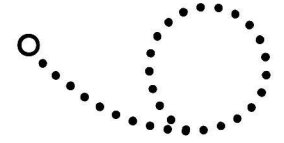
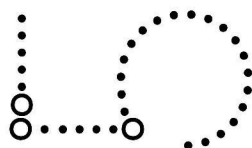
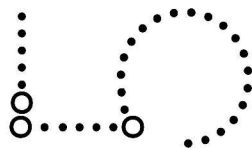
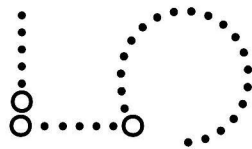
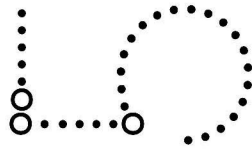
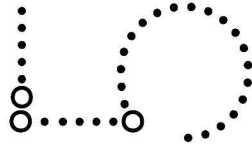
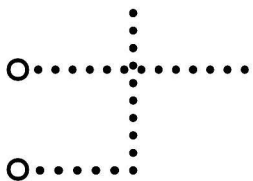
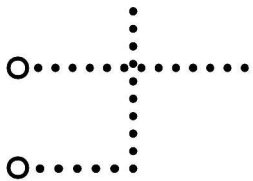
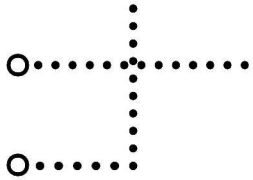
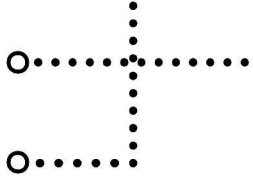
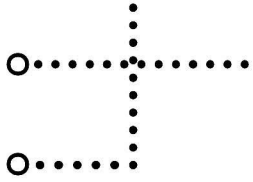





# Back to School

## Tracing Numbers

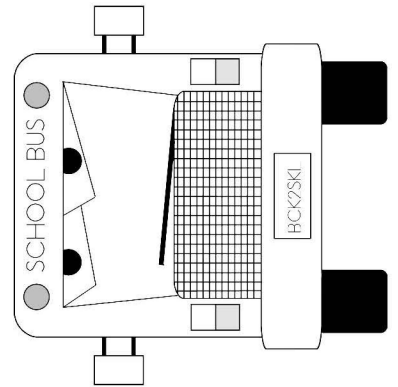
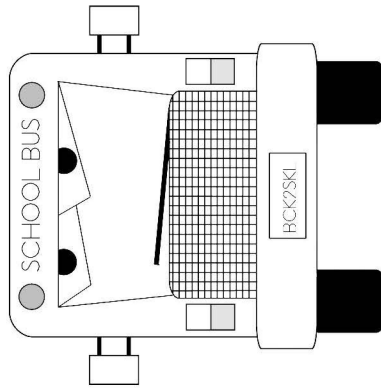
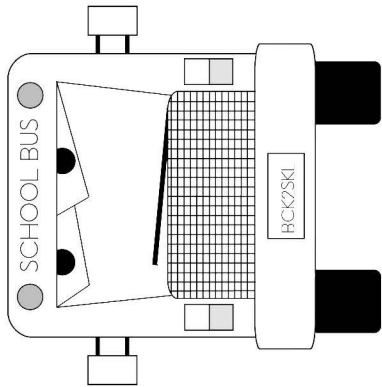
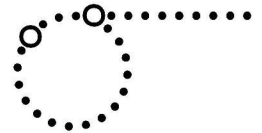
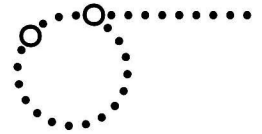
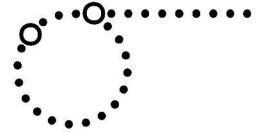
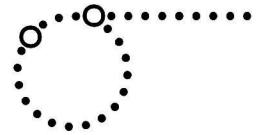
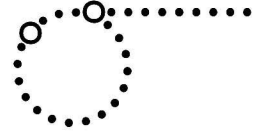
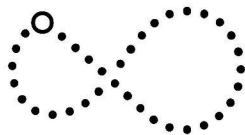
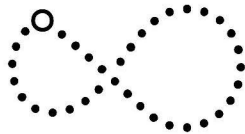
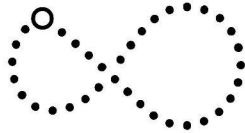
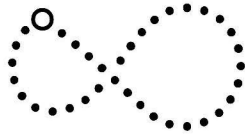
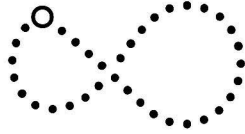
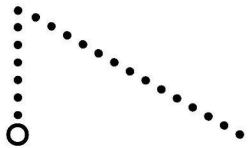
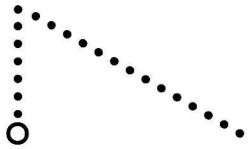
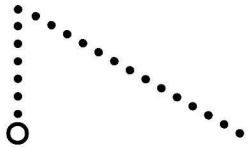
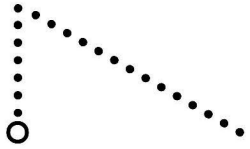
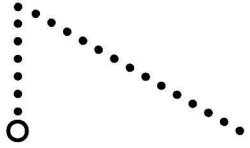



# Back to School

## Tracing Numbers

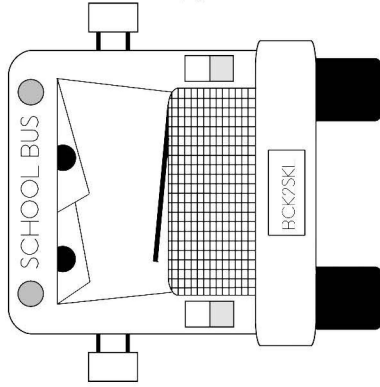
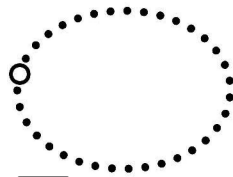
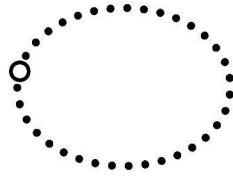
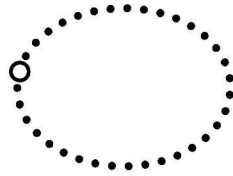
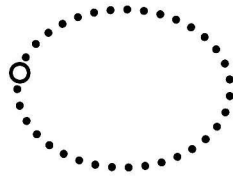
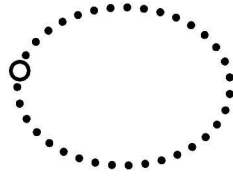
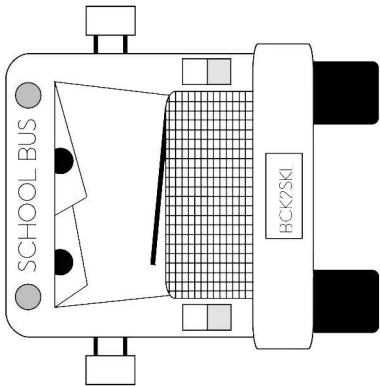
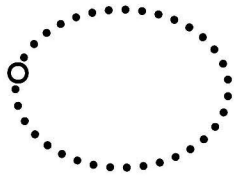
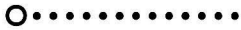

# Tracing Numbers

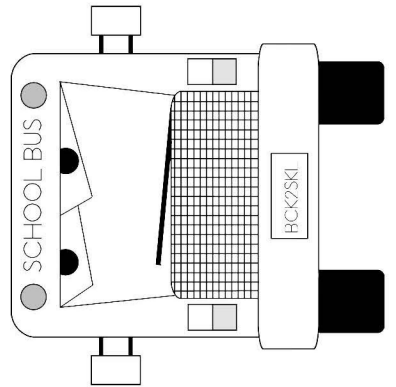



# Back to School Alphabet Tracing Cards

O

A a



O

B b

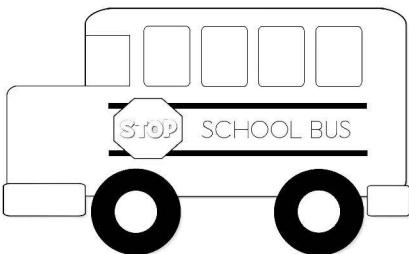

O

C c



O

D d



O

E e



O

F f





# Back to School Alphabet Tracing Cards

O

G g

O

H h

O

I i

O

J j

O

K k

O

L l



# Back to School

## Alphabet Tracing Cards

O

M m

O

N n

O

O o

O

P p

O

Q q

O

R r



# Back to School

## Alphabet Tracing Cards

O

S s

O

T t

O

U u

O

V v

O

W w

O

X x



# Back to School Alphabet Tracing Cards

O

SCHOOL BUS

O

SCHOOL BUS

O

SCHOOL BUS

O

SCHOOL BUS

O

SCHOOL BUS

O

SCHOOL BUS



## My Crayon Book

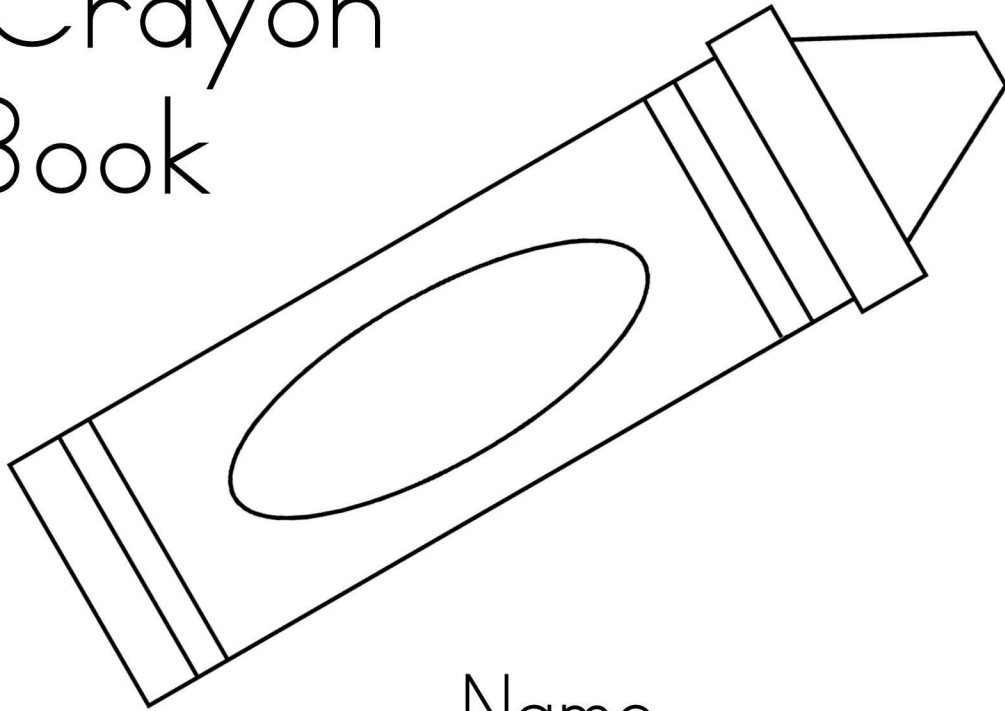

Name: \_\_\_\_\_

I see a brown crayon.

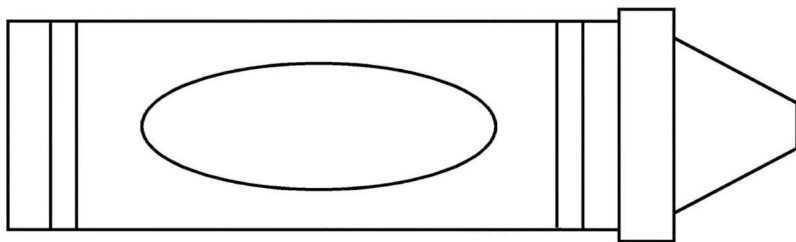



# Color Book - 1

I see a green crayon.

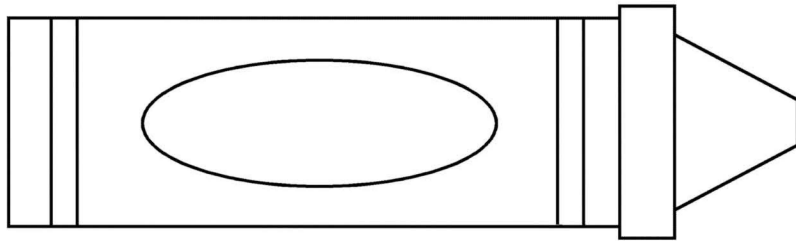

I see a red crayon.

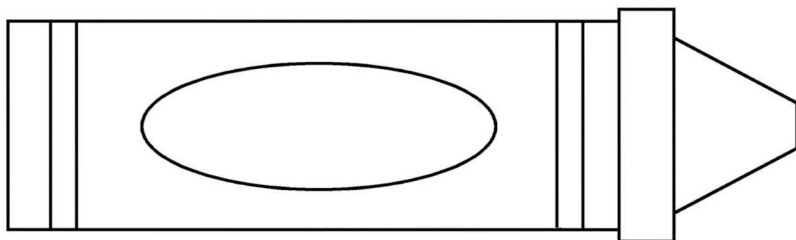

# Color Book - 1

I see a white crayon.

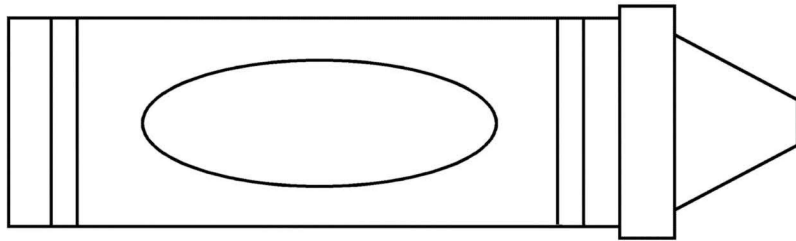

I see a gray crayon.

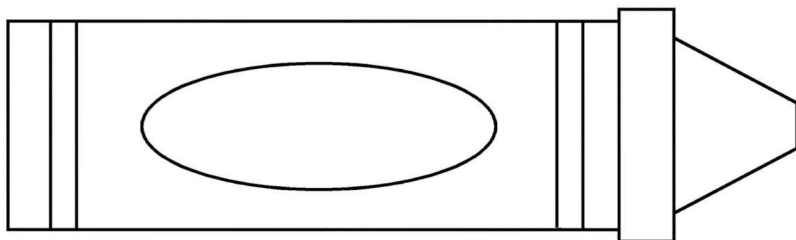

# Color Book - 1

I see a blue crayon.

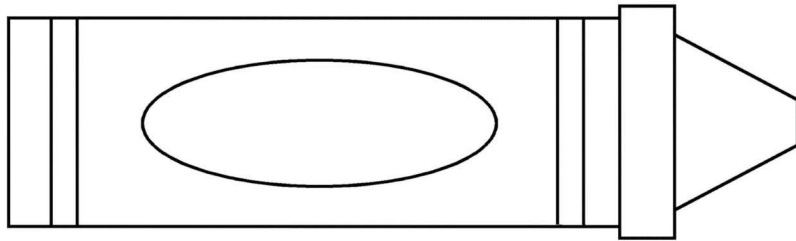

I see an orange crayon.

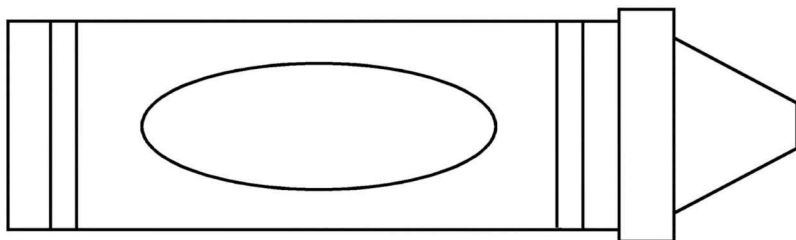



# Color Book - 1

I see a black crayon.

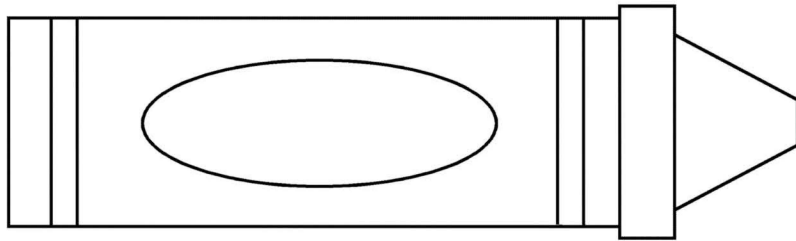

I see a yellow crayon.

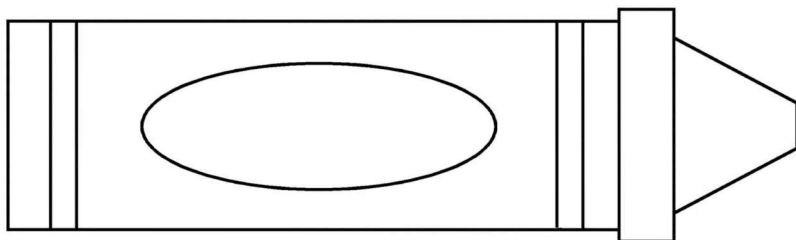



# Color Book - 1

I see a purple crayon.

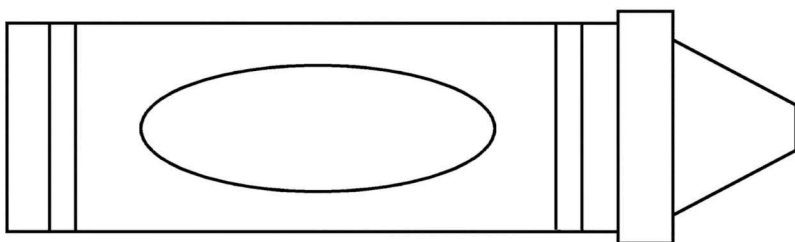
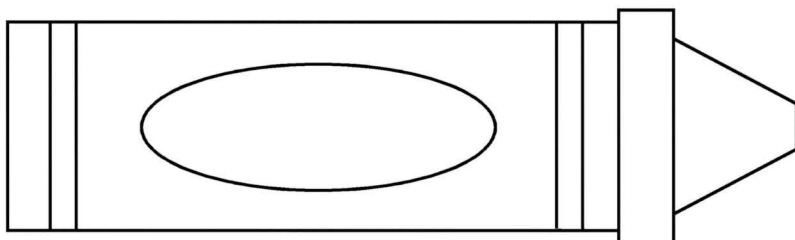

# All About Me

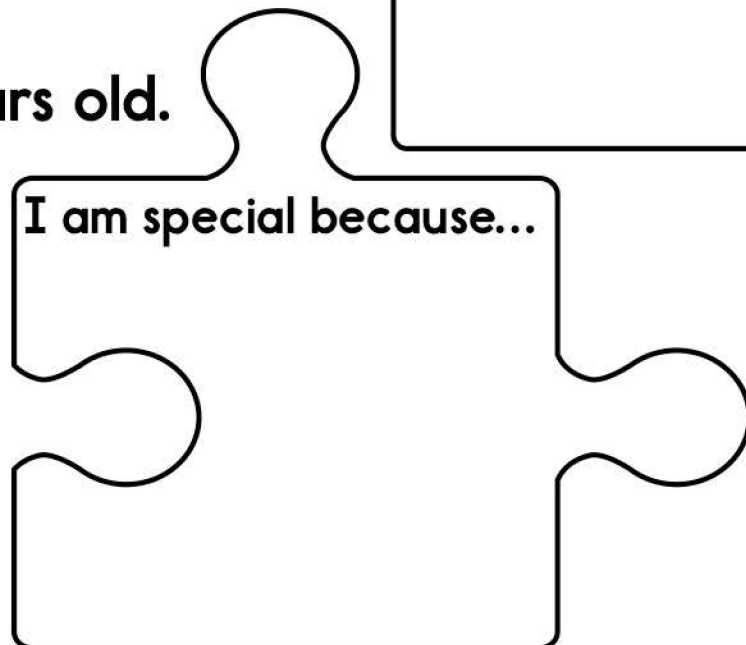
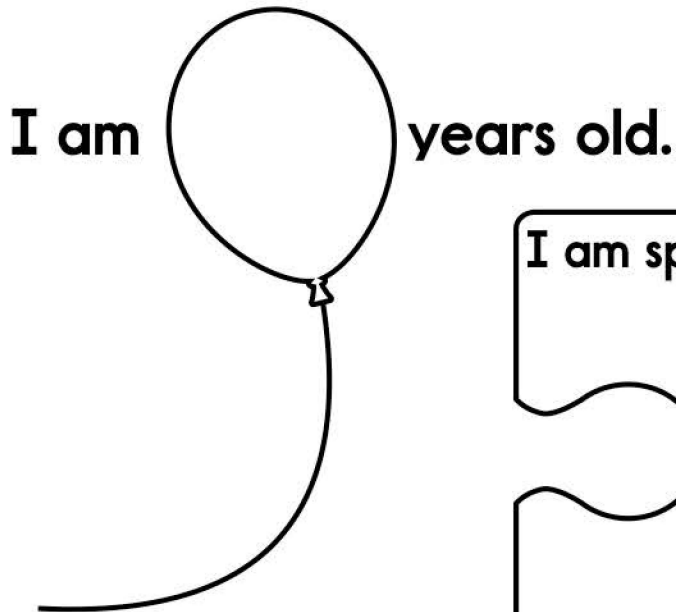
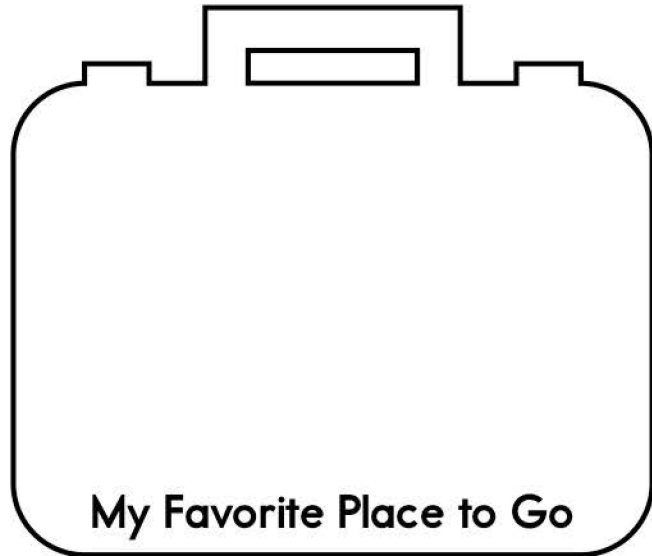
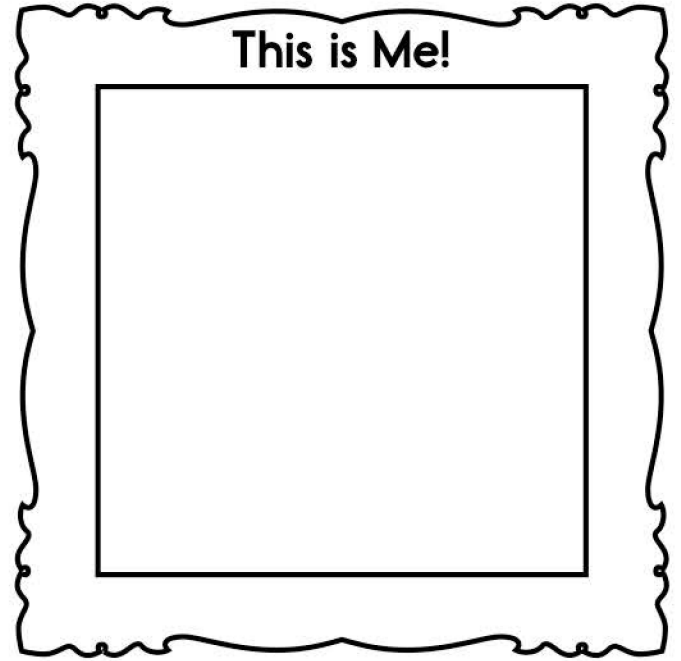
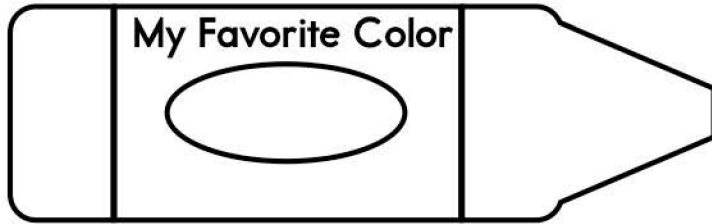
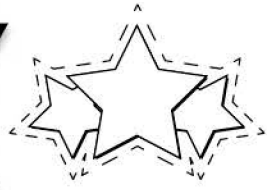
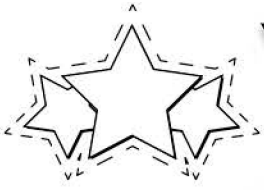

# Alphabet Board

A	B	C	D	E
F	G	H	I	J
K	L	M	N	O
P	Q	R	S	T
U	V	W	X	Y
Z				

Cut Out Letters. Place Matching Letters on the Alphabet Board.

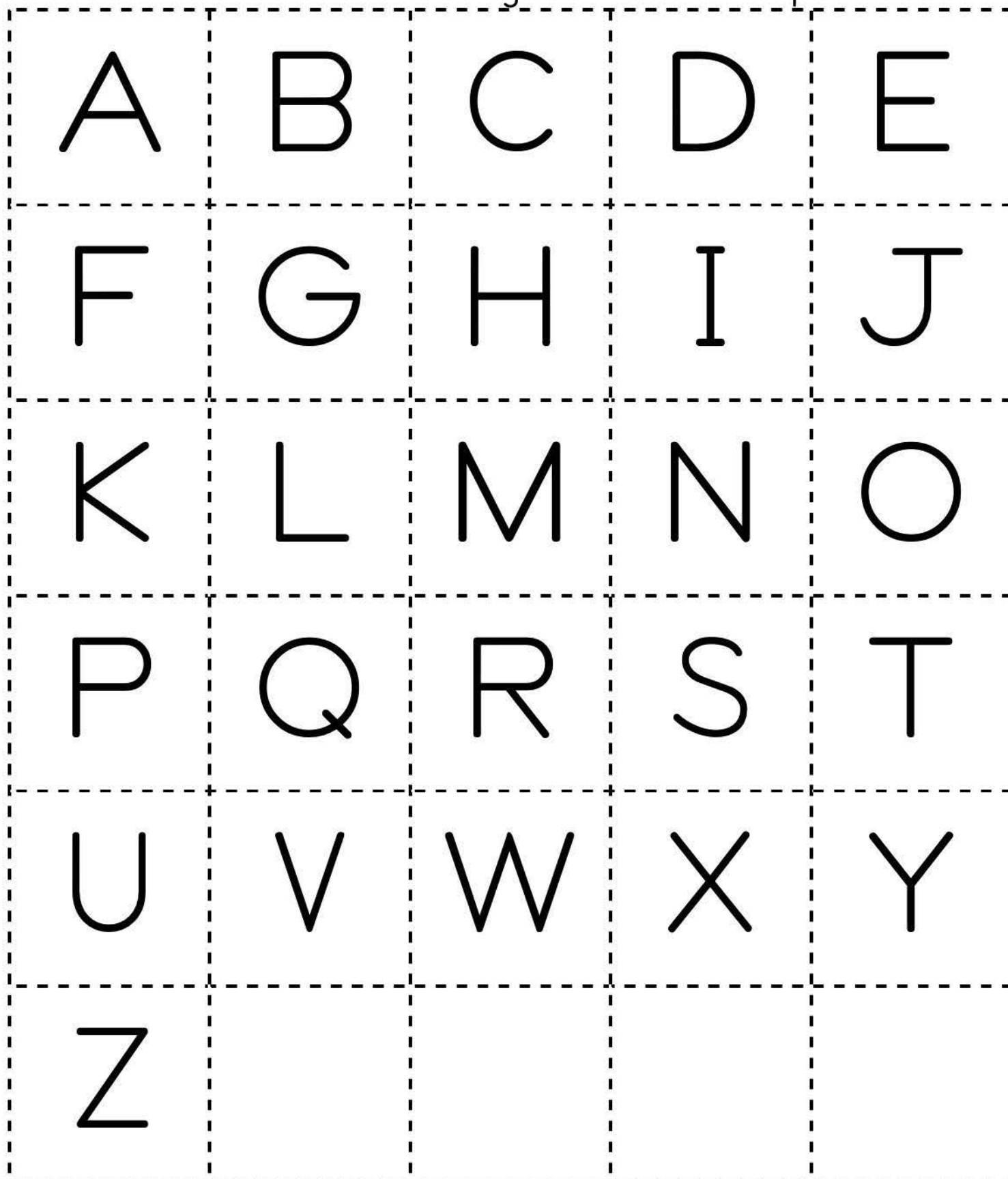





# Body Part Bingo

Play BINGO to practice identifying parts of the body. Each player receives a BINGO board and bingo chips to cover the board. Place picture cards in a bag to draw from. Either a player or the teacher can be the BINGO caller. Choose a game type:

- Straight Line
- Four Corners
- T or I shaped

Call out the body part but do not show the BINGO players. Players must find that body part on their board and cover it. The first player to correctly call out BINGO is the winner!

# B I N G O

[www.HaveFunTeaching.com](http://www.HaveFunTeaching.com)

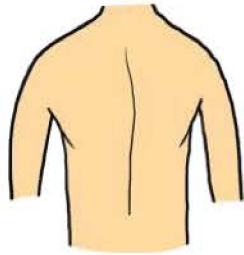
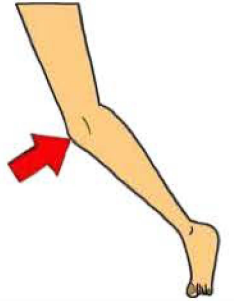
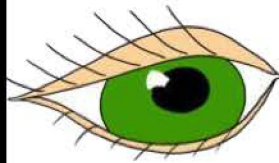
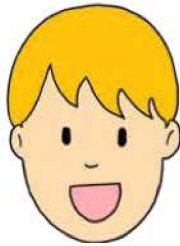
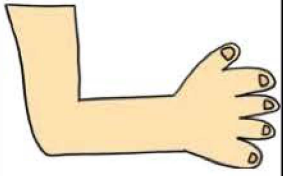

Free Space

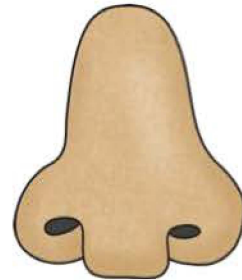
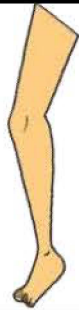
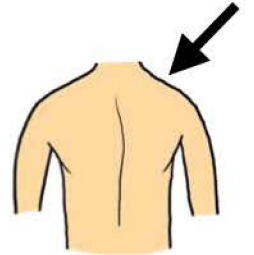

# B I N G O

[www.HaveFunTeaching.com](http://www.HaveFunTeaching.com)

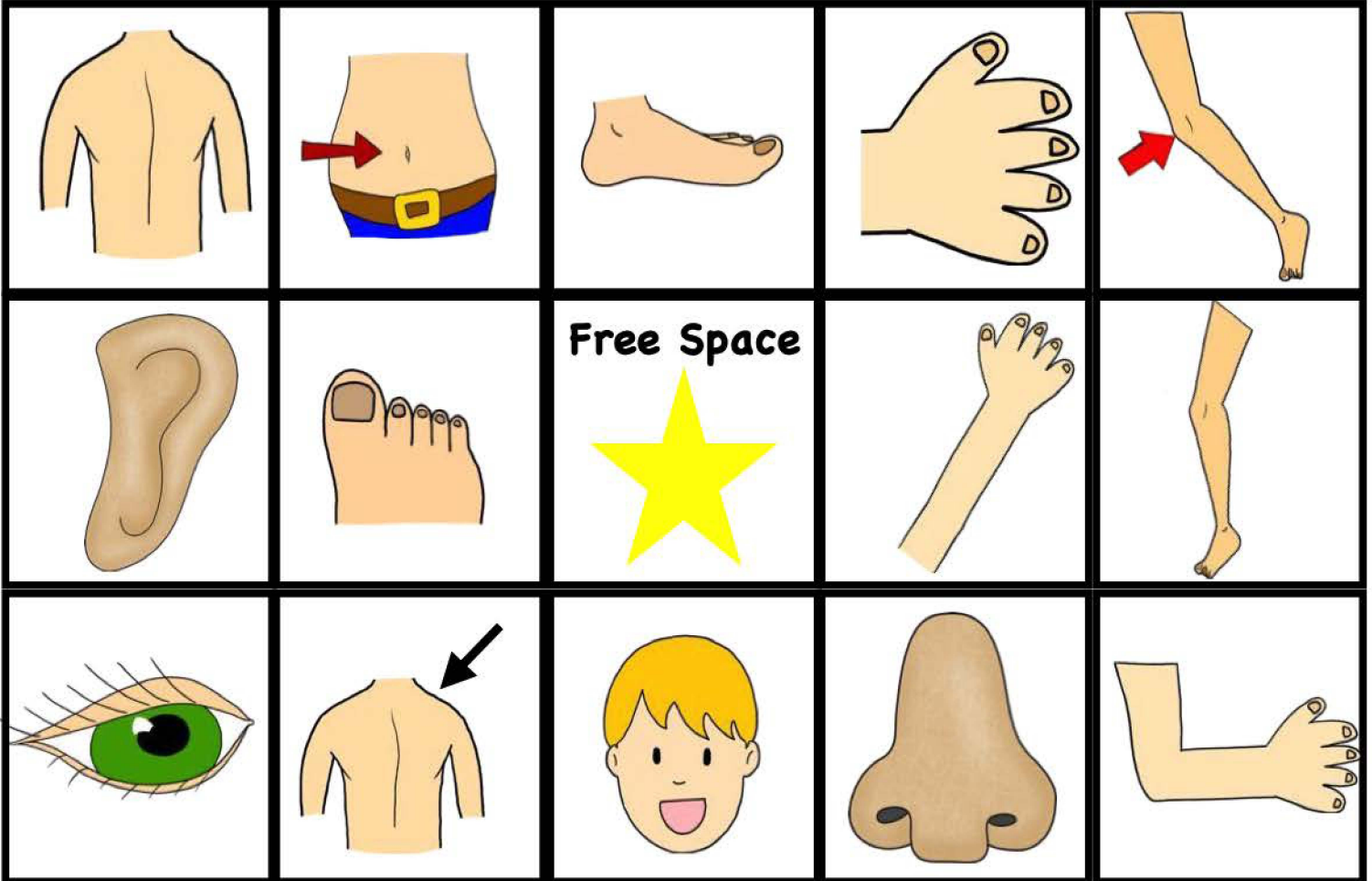



# B I N G O

[www.HaveFunTeaching.com](http://www.HaveFunTeaching.com)

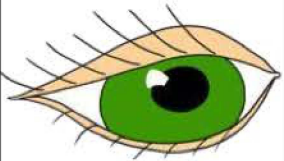
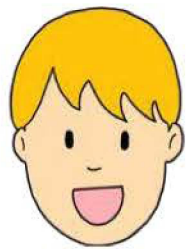
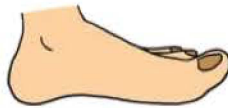
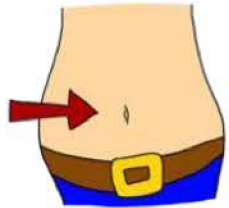
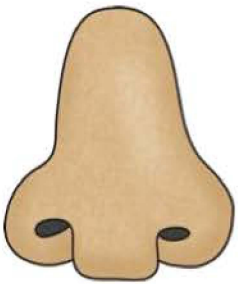



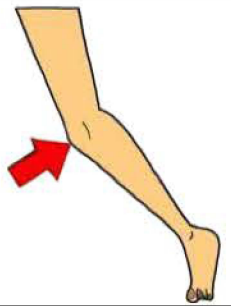
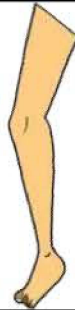
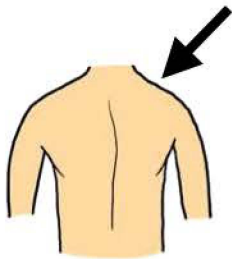
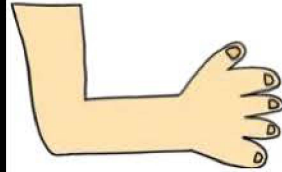





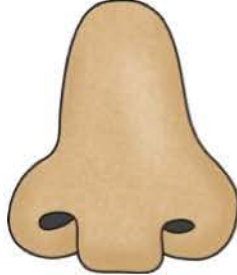

Free Space

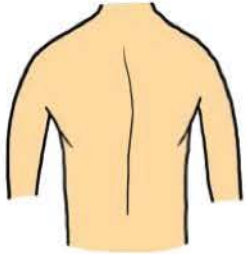

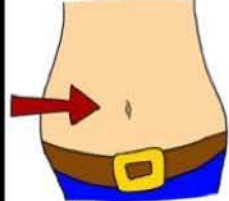
# B I N G O

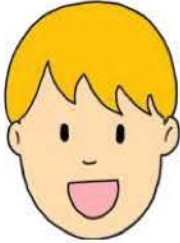
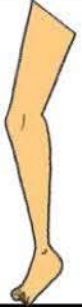
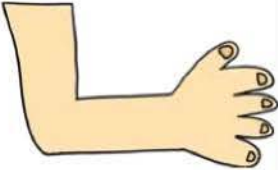
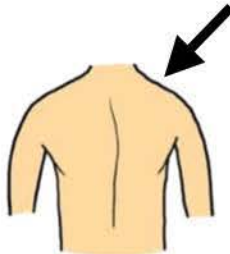
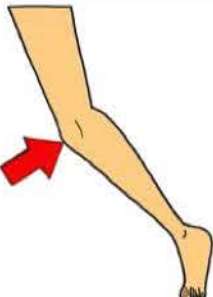
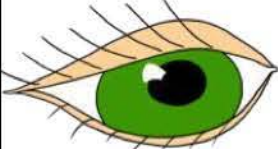
[www.HaveFunTeaching.com](http://www.HaveFunTeaching.com)

				
		<p>Free Space</p> 		
				

# B I N G O

[www.HaveFunTeaching.com](http://www.HaveFunTeaching.com)

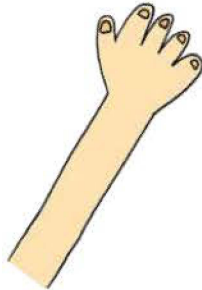
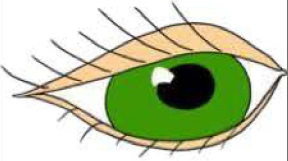
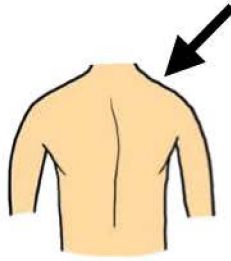
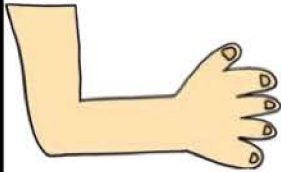
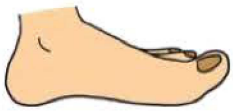



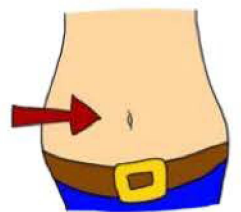
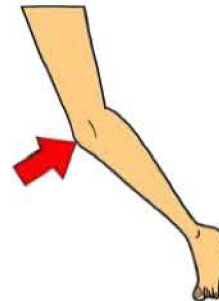
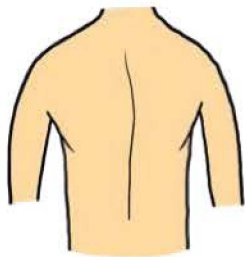
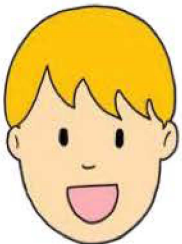
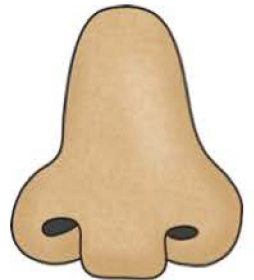
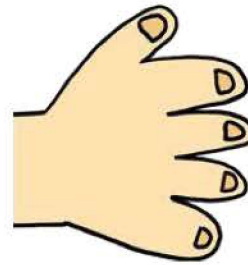



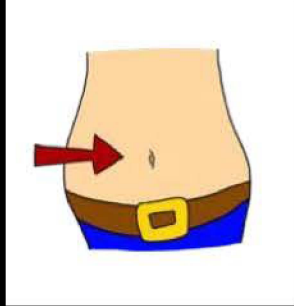
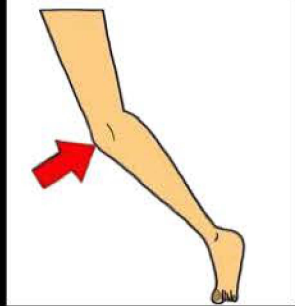
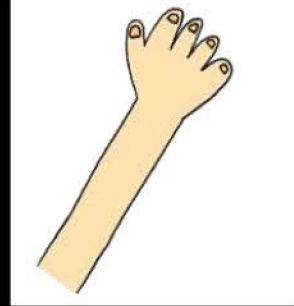
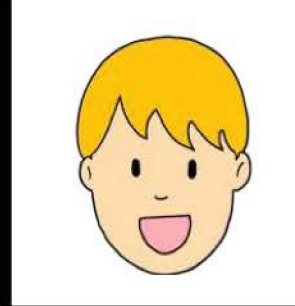
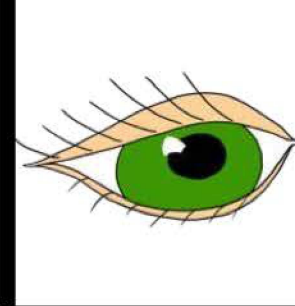
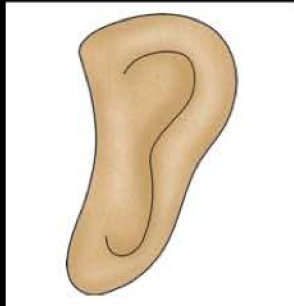

Free Space

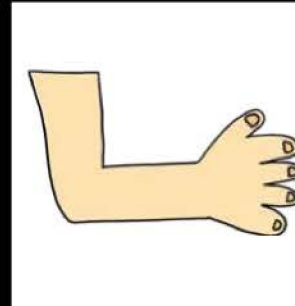
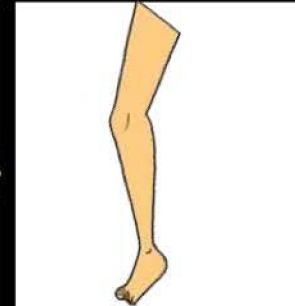



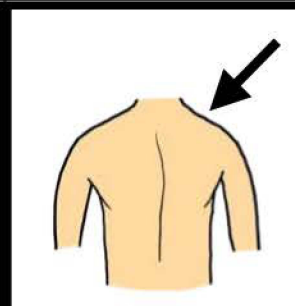





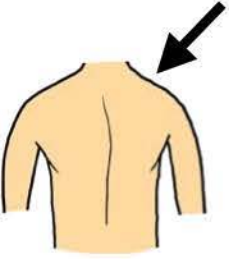

# B I N G O

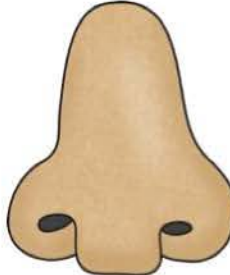
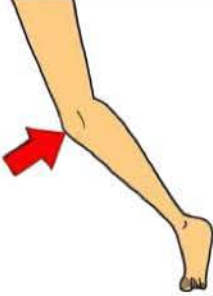
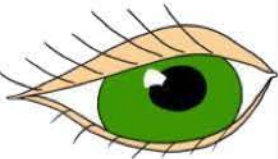
[www.HaveFunTeaching.com](http://www.HaveFunTeaching.com)

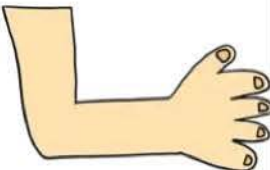
				
		<p>Free Space</p> 		
				

# B I N G O

[www.HaveFunTeaching.com](http://www.HaveFunTeaching.com)

				
		<p>Free Space</p> 		
				



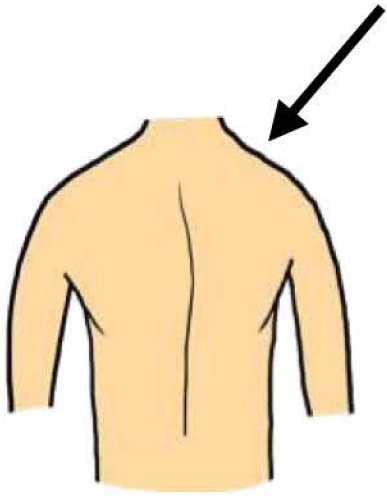

[www.HaveFunTeaching.com](http://www.HaveFunTeaching.com)

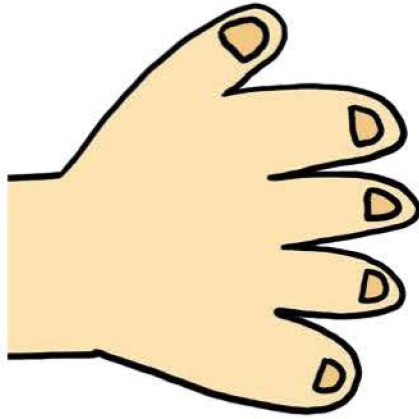

[www.HaveFunTeaching.com](http://www.HaveFunTeaching.com)



[www.HaveFunTeaching.com](http://www.HaveFunTeaching.com)

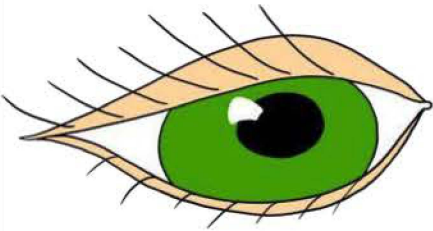

[www.HaveFunTeaching.com](http://www.HaveFunTeaching.com)

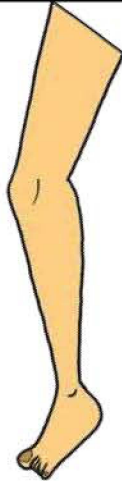

[www.HaveFunTeaching.com](http://www.HaveFunTeaching.com)

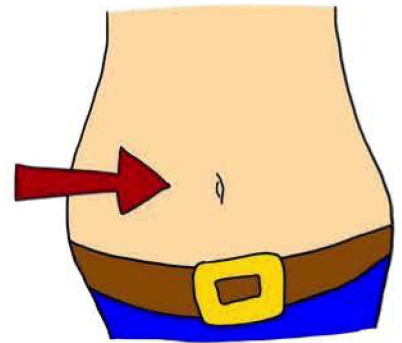

[www.HaveFunTeaching.com](http://www.HaveFunTeaching.com)

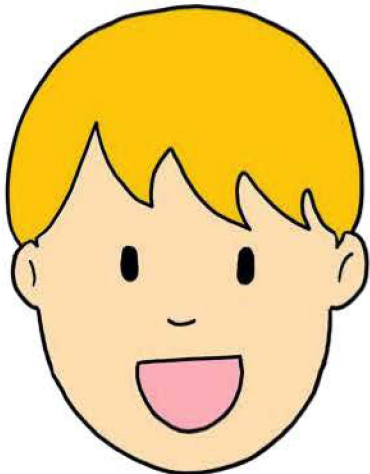

[www.HaveFunTeaching.com](http://www.HaveFunTeaching.com)

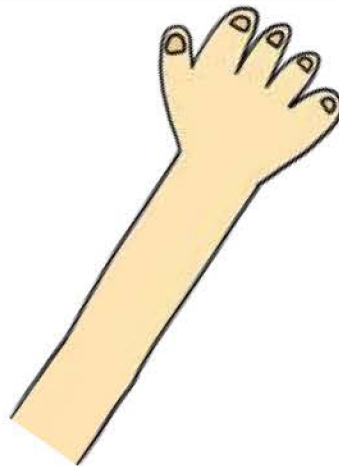

[www.HaveFunTeaching.com](http://www.HaveFunTeaching.com)

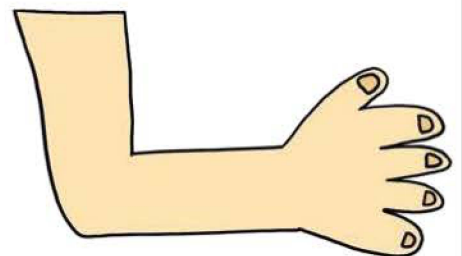

[www.HaveFunTeaching.com](http://www.HaveFunTeaching.com)

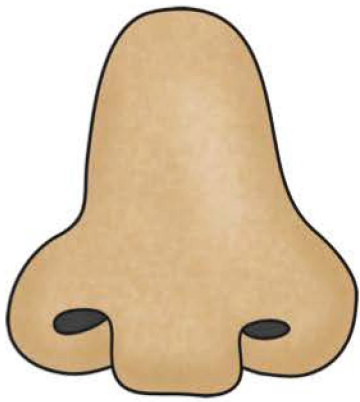

[www.HaveFunTeaching.com](http://www.HaveFunTeaching.com)

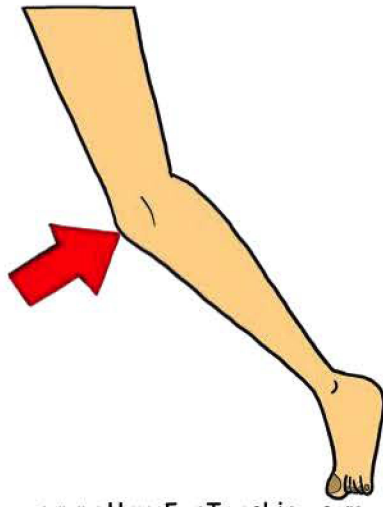

[www.HaveFunTeaching.com](http://www.HaveFunTeaching.com)

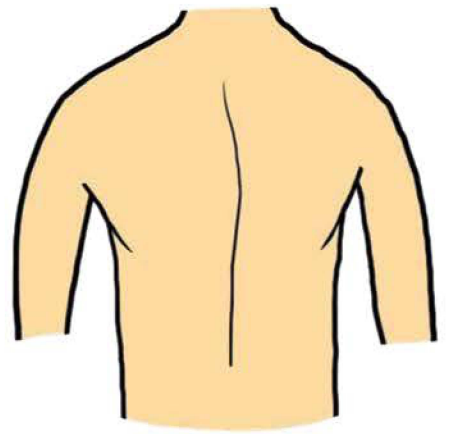

[www.HaveFunTeaching.com](http://www.HaveFunTeaching.com)



[www.HaveFunTeaching.com](http://www.HaveFunTeaching.com)

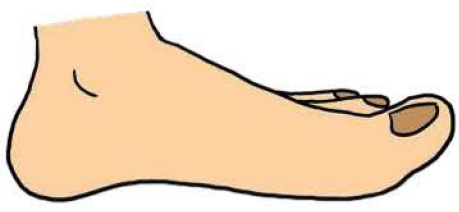

[www.HaveFunTeaching.com](http://www.HaveFunTeaching.com)



# Practicing curves

Connect the dots to complete the picture.  
Start at each big dot, and follow the arrow.

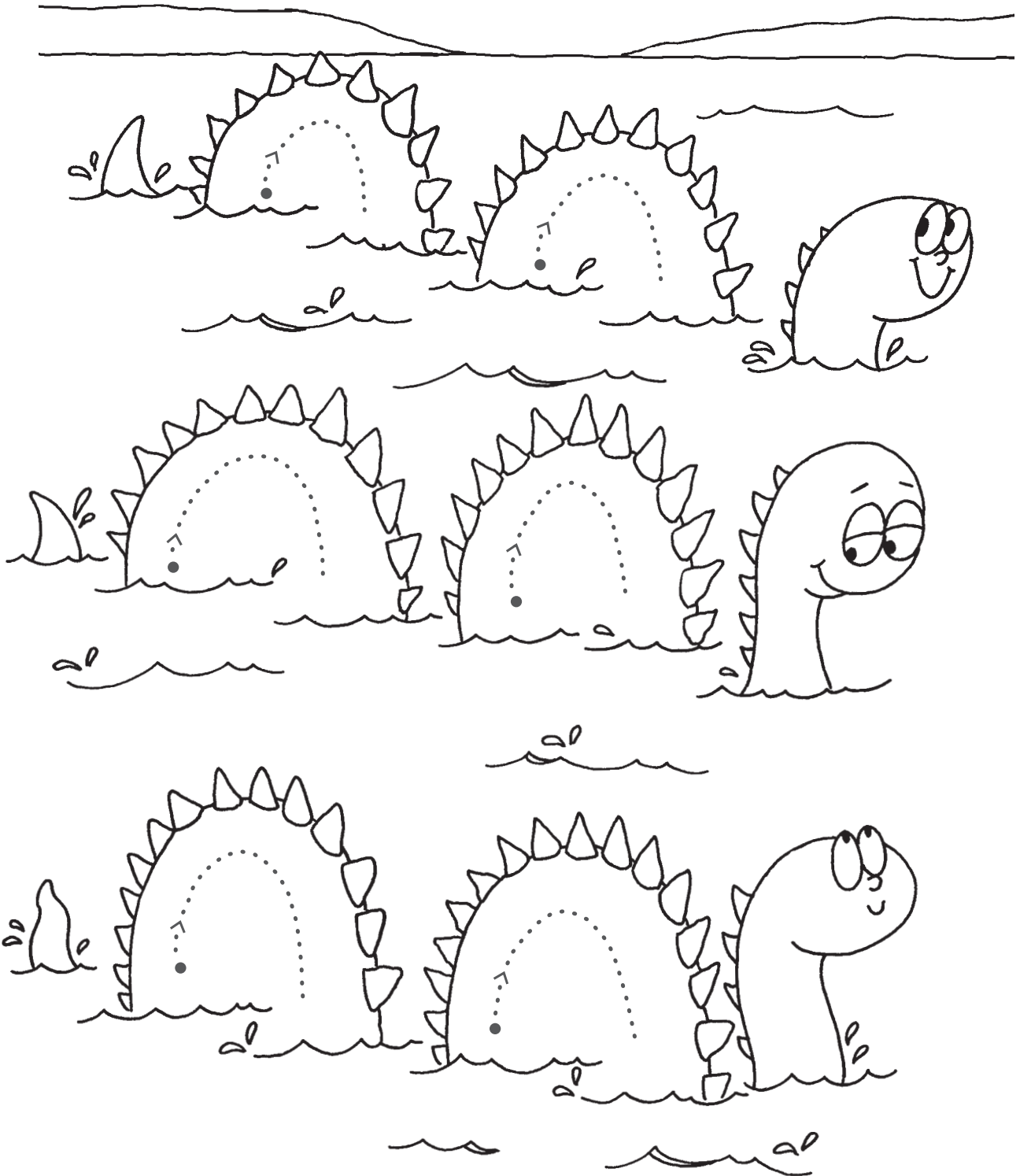

# Practicing curves



Connect the dots to complete the picture.  
Start at each big dot, and follow the arrow.

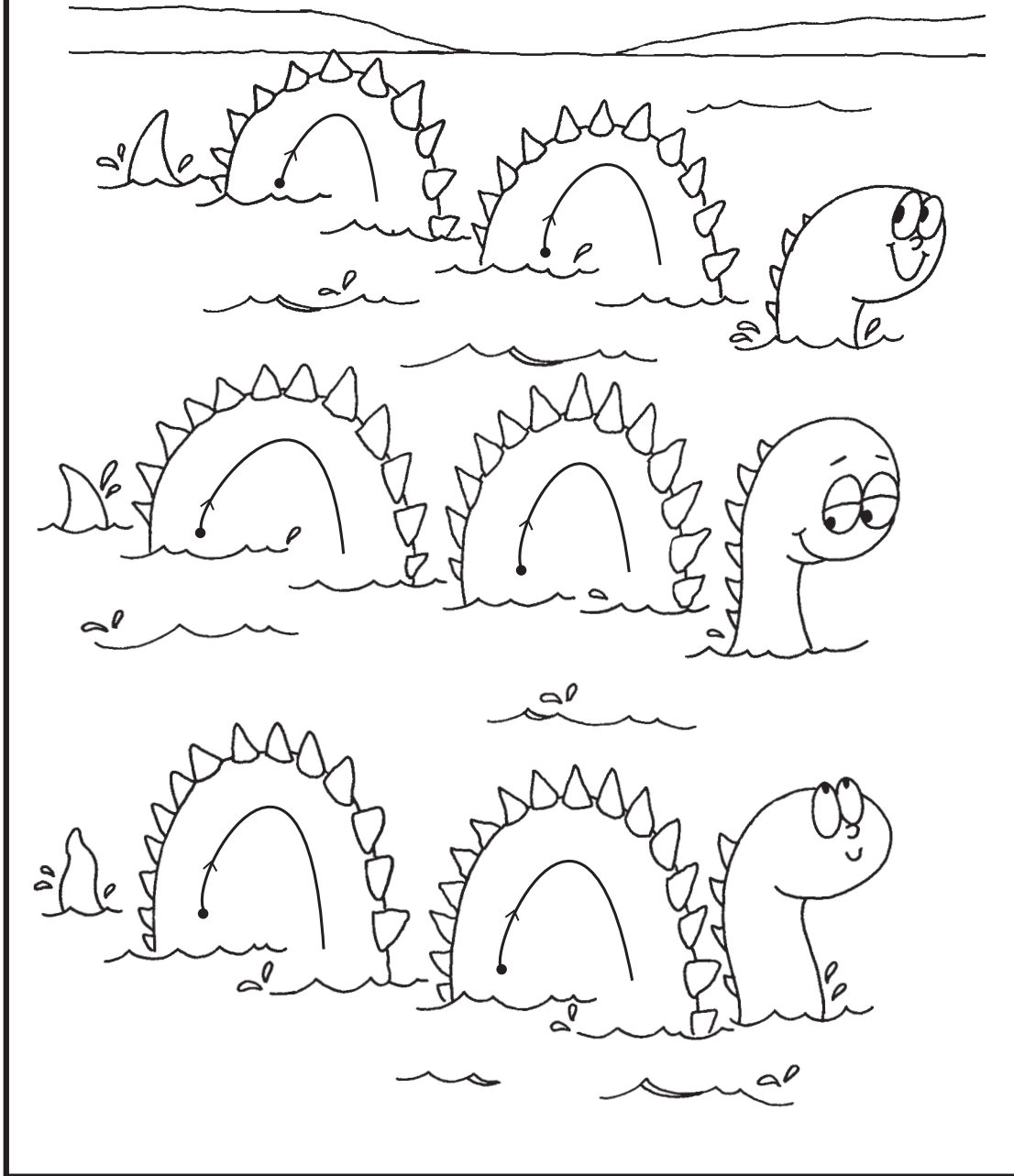

In this activity, your child connects the dots starting with the big dot to form curves. Encourage him or her to practice a fluid movement and to keep the pencil moving. Talk about the shapes and patterns that your child is creating. These pictures are also fun for your child to color and complete.

# Practicing curvy lines



Connect the dots to complete the picture.  
Start at each big dot, and follow the arrows.

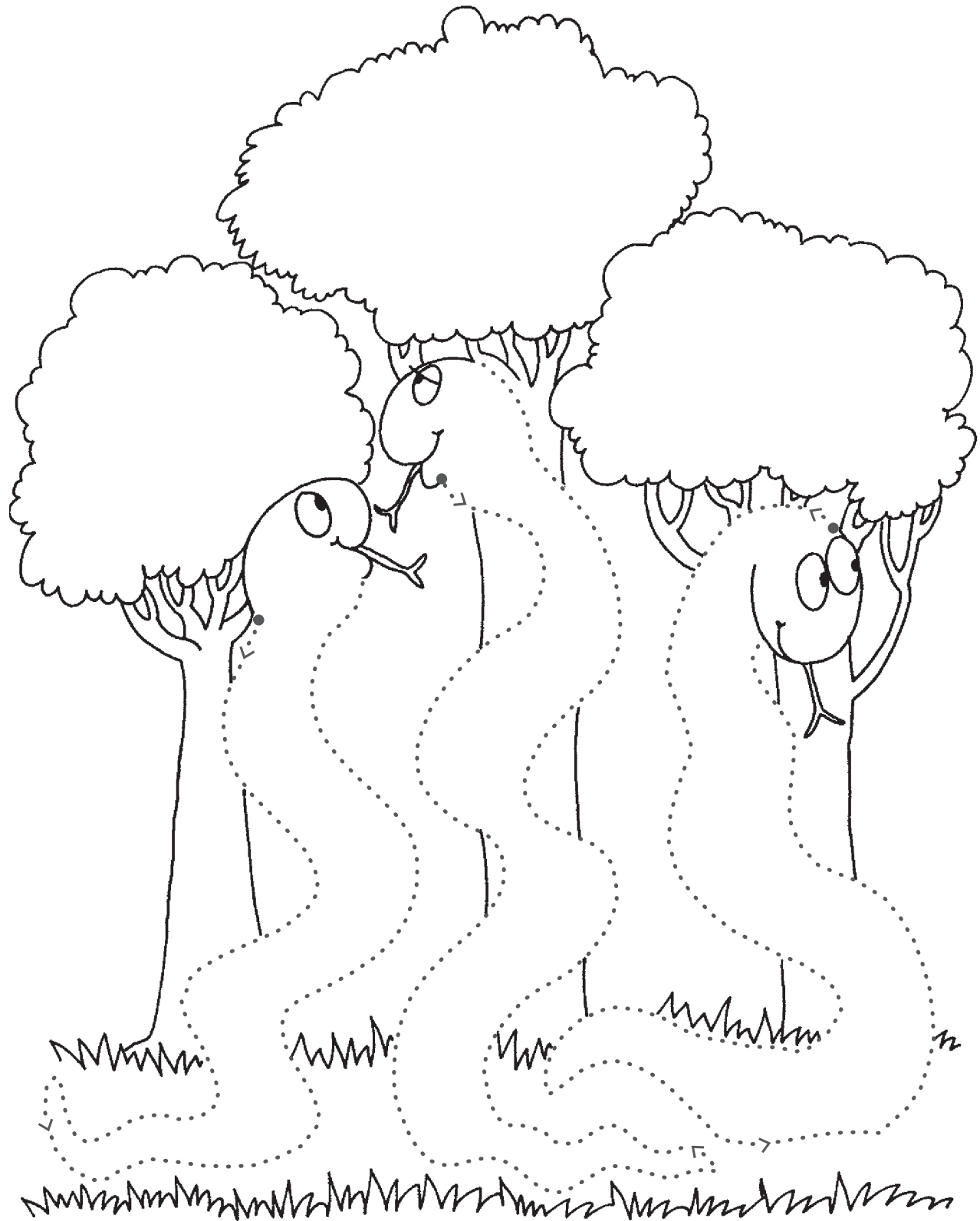

# Practicing curvy lines



Connect the dots to complete the picture.  
Start at each big dot, and follow the arrows.

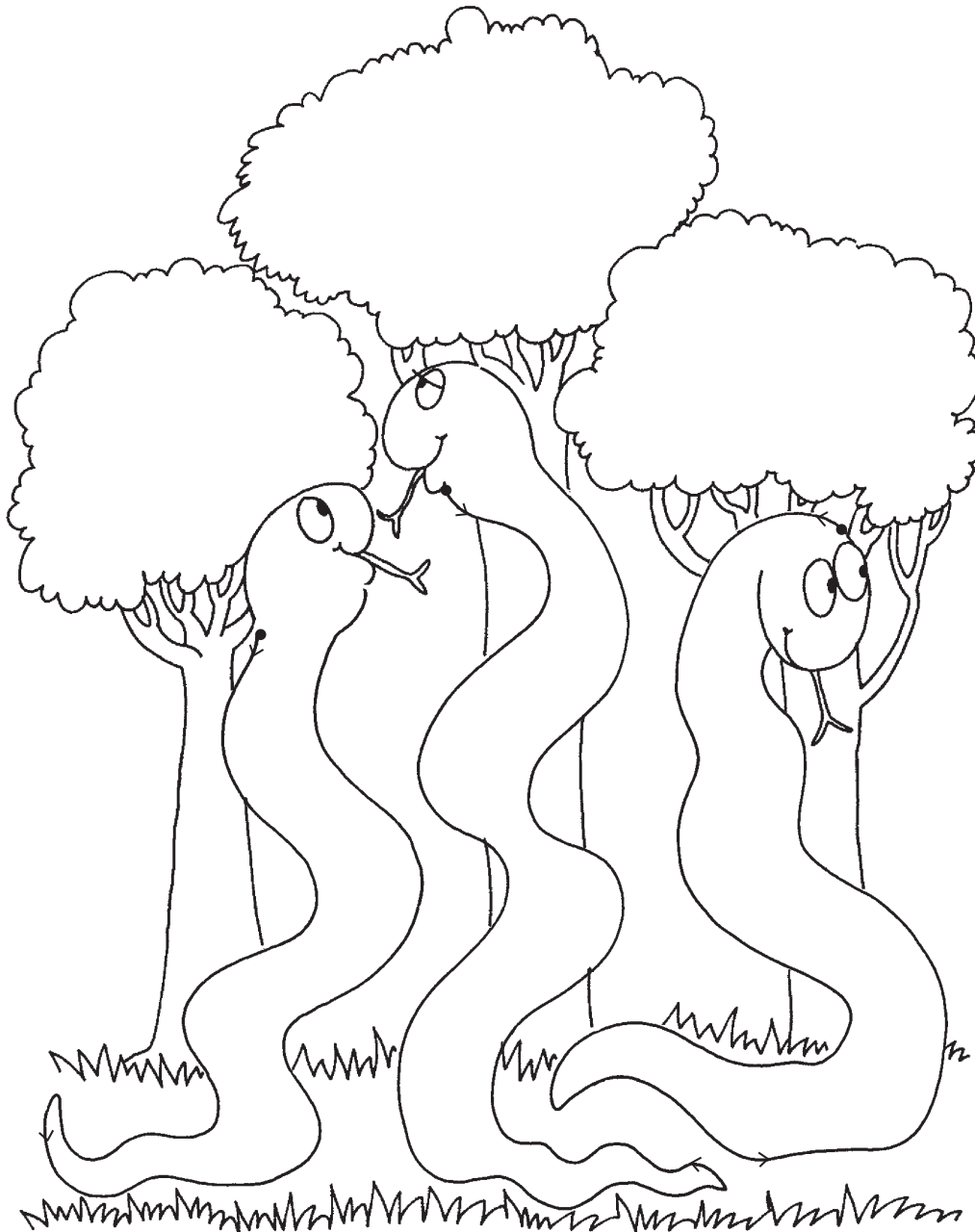





In this activity, your child connects the dots starting with the big dot to form curvy lines. Encourage him or her to practice a fluid movement and to keep the pencil moving. Talk about the shapes and patterns that your child is creating. These pictures are also fun for your child to color and complete.

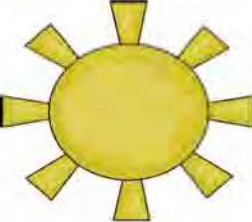

Name: \_\_\_\_\_

# CVC Word Sounds

**Directions:** Look at the pictures below. Say the words. Think about beginning, middle, and ending sounds. Choose the word that matches each picture. Trace the correct word.

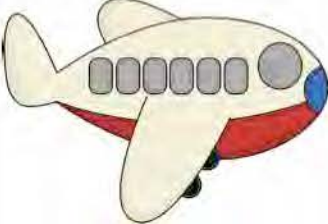
	log	dog	dot
	sun	fun	sub
	bat	cat	can
	bet	bun	bus
	peg	pig	wig
	jet	jam	bet

# Draw and color



Draw a bigger circle.

Color it blue.

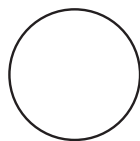

Draw a longer rectangle.

Color it green.

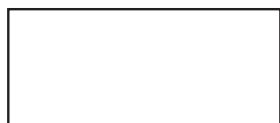

Draw a bigger triangle.

Color it red.



Draw a thicker rectangle.

Color it yellow.



Draw a bigger square.

Color it blue.

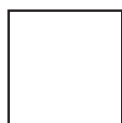





# Practicing wavy lines

Connect the dots to complete the picture.  
Start at each big dot, and follow the arrows.

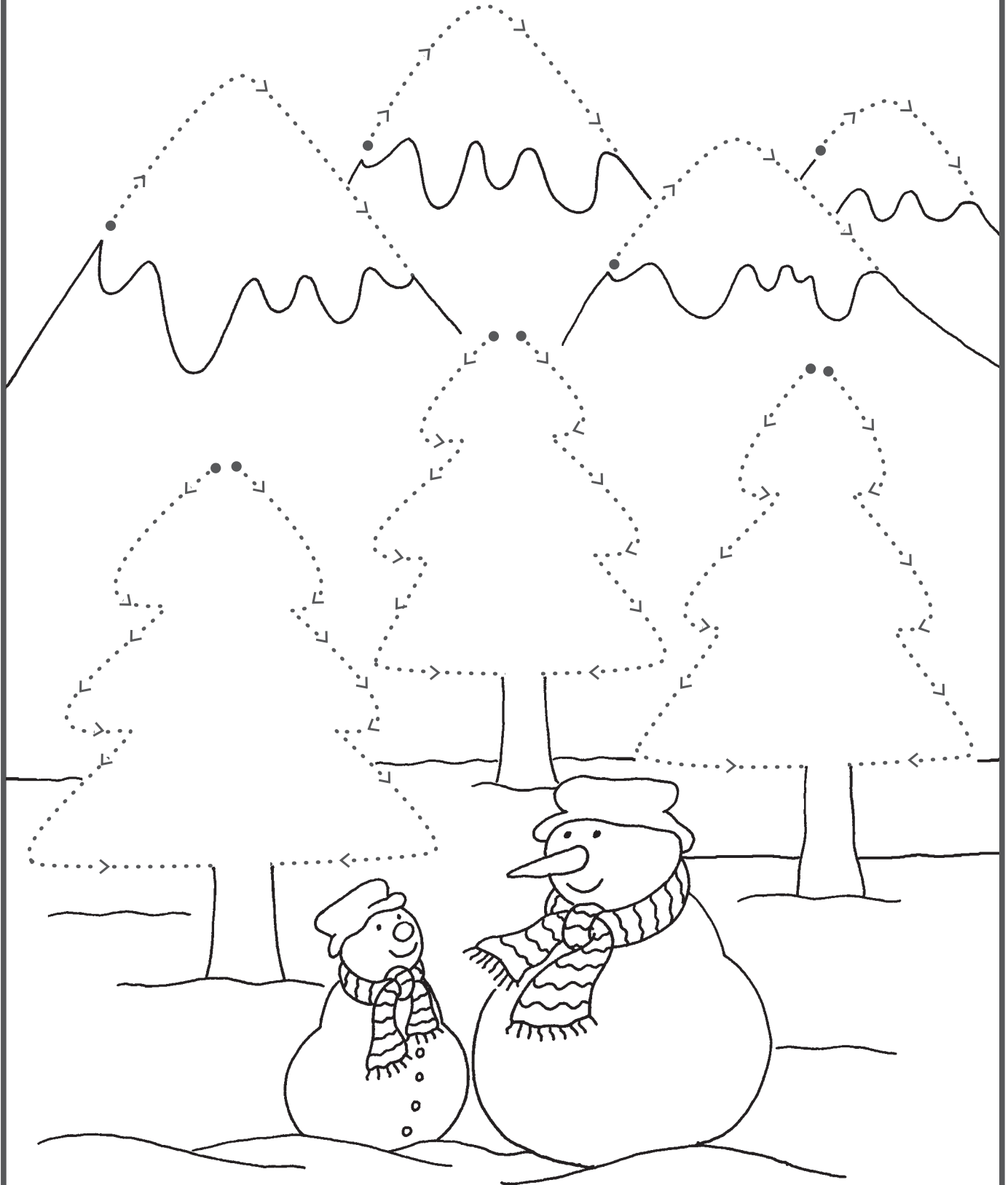



# Practicing wavy lines

Connect the dots to complete the picture.  
Start at each big dot, and follow the arrows.

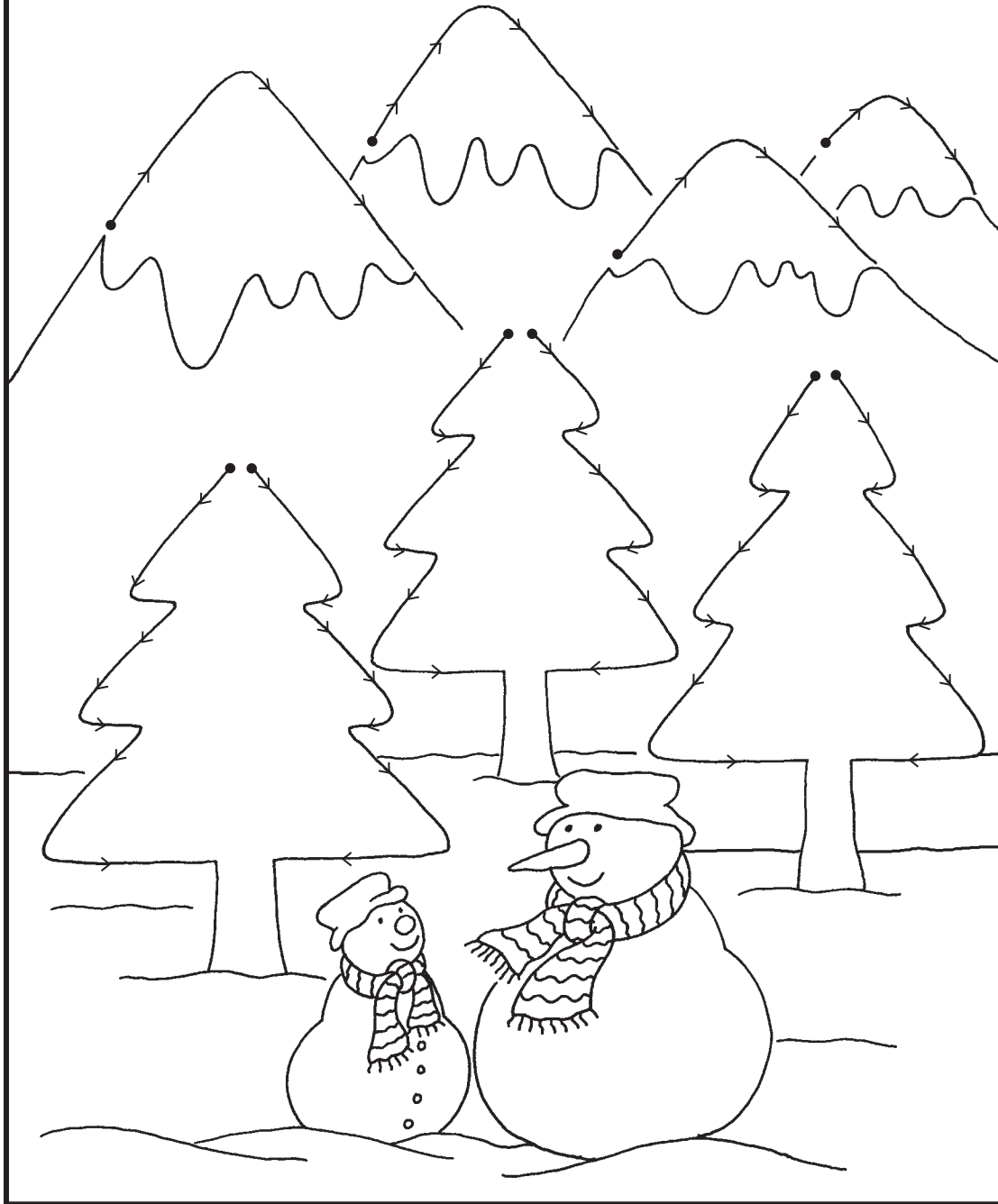

In this activity, your child connects the dots starting with the big dot to form wavy lines. Encourage him or her to practice a fluid movement and to keep the pencil moving. Talk about the shapes and patterns that your child is creating. These pictures are also fun for your child to color and complete.



# Tall, taller, tallest

A tall bottle



Draw a taller bottle.

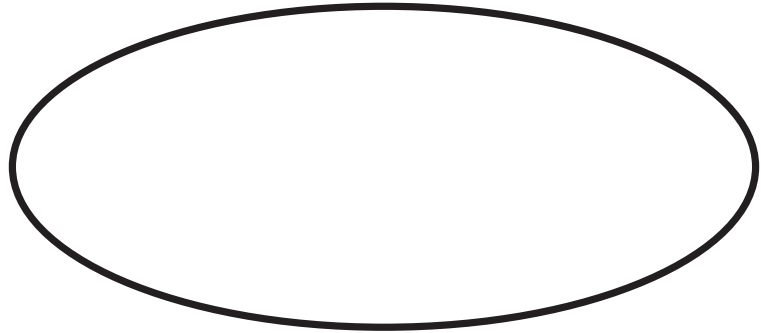

A tall flower



Draw a taller flower.

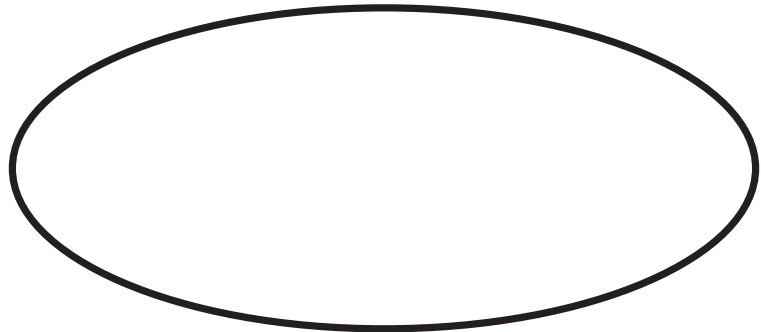

✓ the tallest.



# Small, smaller, smallest



Small cup cake

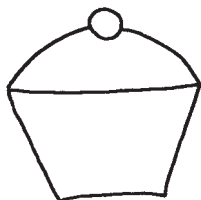

Draw a smaller cup cake.

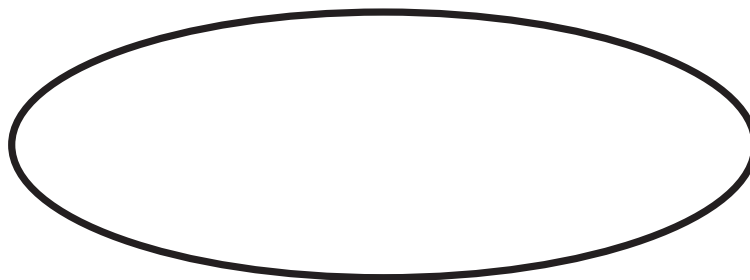

Small cup

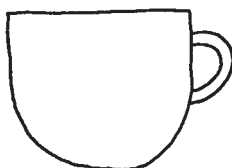

Draw a smaller cup.

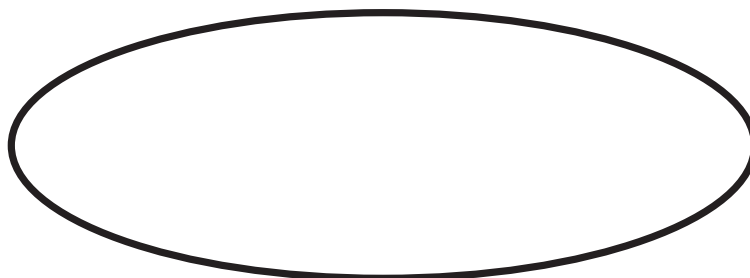



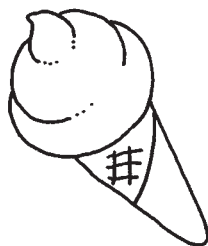





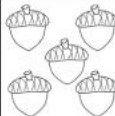

✓ the smallest.

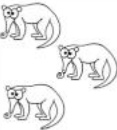

# Alphabet & Counting

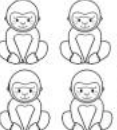

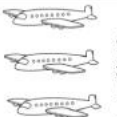





Name \_\_\_\_\_ Aa

Count the objects. Circle the correct answer.

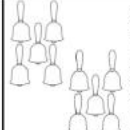
	1 2 3 4 5		1 2 3 4 5		1 2 3 4 5
	1 2 3 4 5		1 2 3 4 5		1 2 3 4 5
	1 2 3 4 5		1 2 3 4 5		1 2 3 4 5
	1 2 3 4 5		1 2 3 4 5		1 2 3 4 5

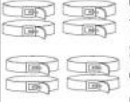
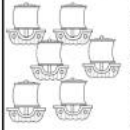
Name \_\_\_\_\_ Bb

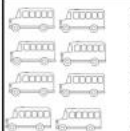
Count the objects. Circle the correct answer.

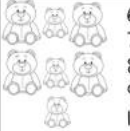

	6 7 8 9 10		6 7 8 9 10		6 7 8 9 10
	6 7 8 9 10		6 7 8 9 10		6 7 8 9 10
	6 7 8 9 10		6 7 8 9 10		6 7 8 9 10
	6 7 8 9 10		6 7 8 9 10		6 7 8 9 10



© Miss Campos 2018

Name \_\_\_\_\_

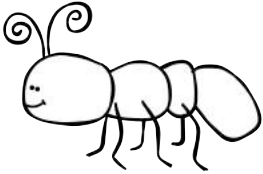
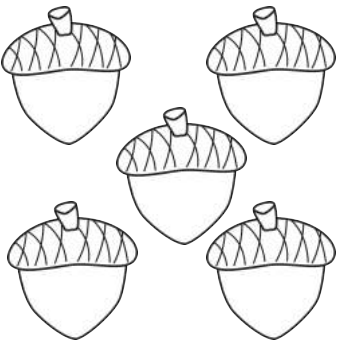
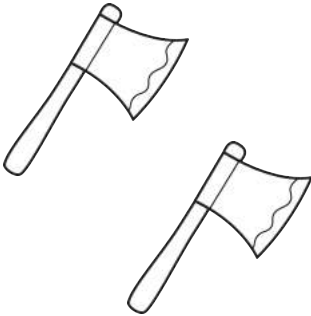
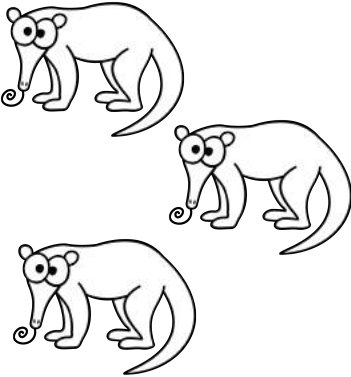
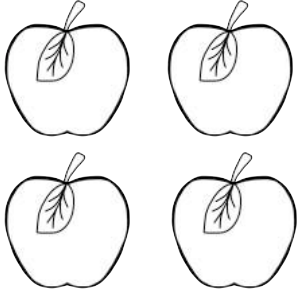

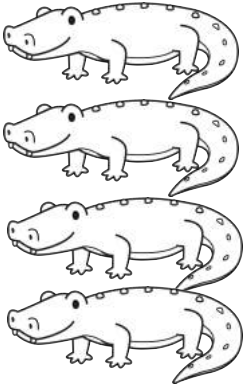
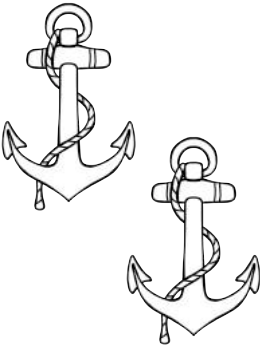
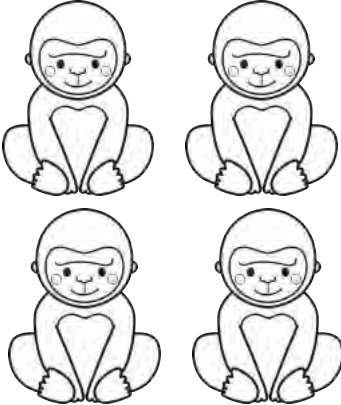
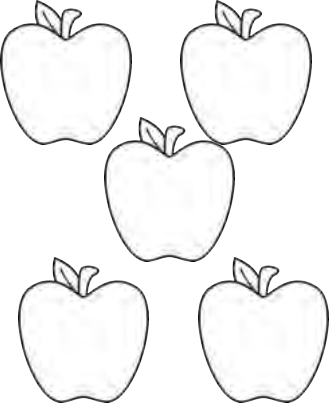
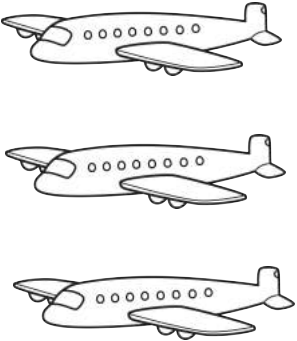
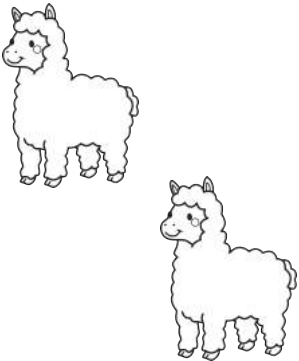
Count the objects. Circle the correct answer.

Name \_\_\_\_\_

Count the objects. Circle the correct answer.



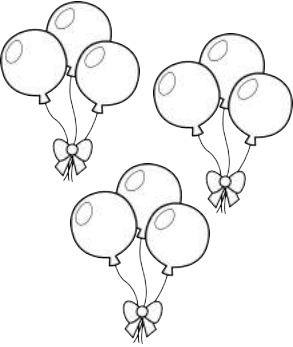
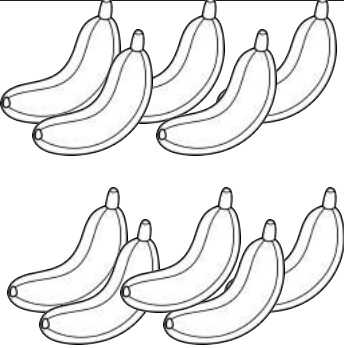
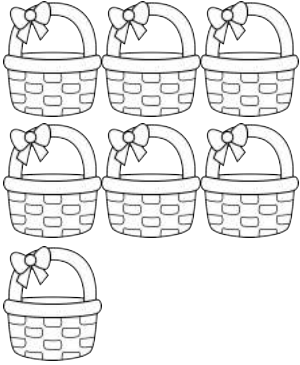
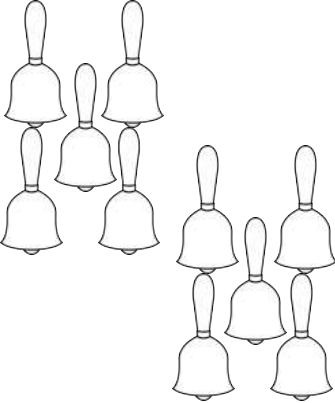

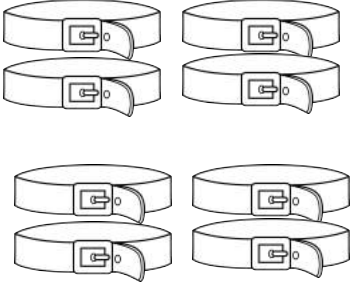
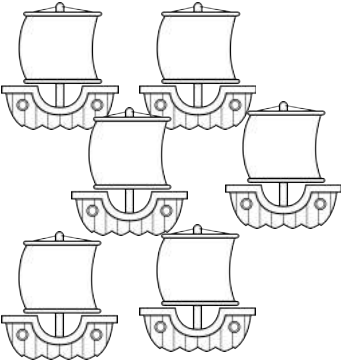
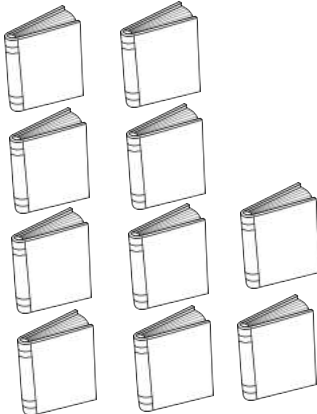
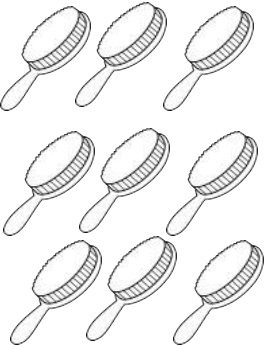
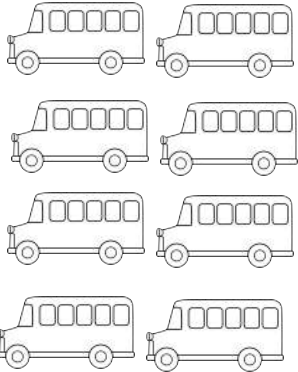
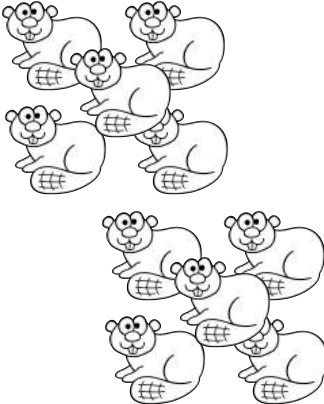
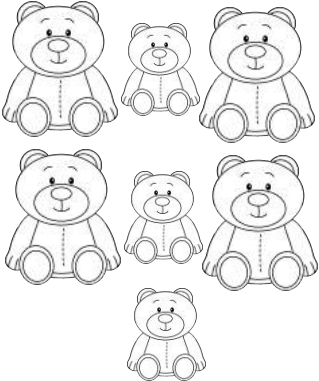

©www.misscampos.com

	<p>6 7 8 9 10</p>		<p>6 7 8 9 10</p>		<p>6 7 8 9 10</p>
	<p>6 7 8 9 10</p>		<p>6 7 8 9 10</p>		<p>6 7 8 9 10</p>
	<p>6 7 8 9 10</p>		<p>6 7 8 9 10</p>		<p>6 7 8 9 10</p>
	<p>6 7 8 9 10</p>		<p>6 7 8 9 10</p>		<p>6 7 8 9 10</p>

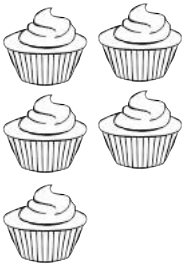

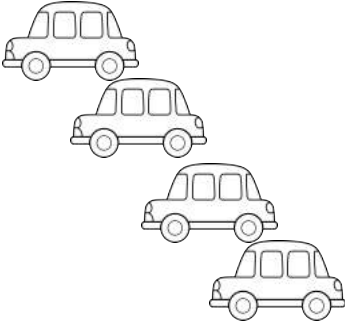
Name \_\_\_\_\_

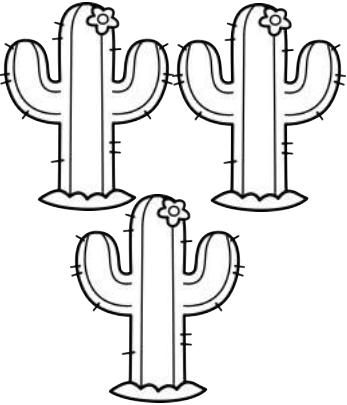
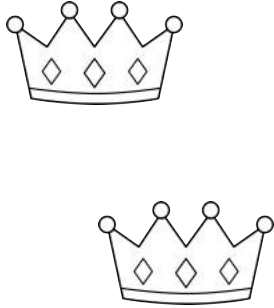
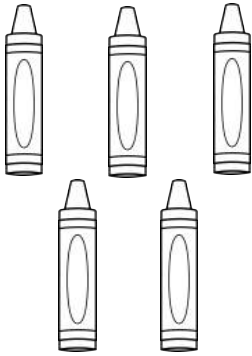
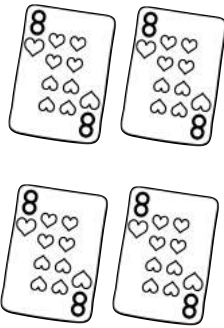
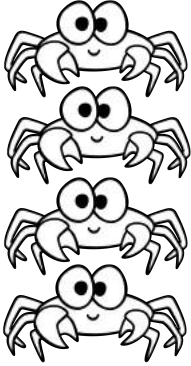

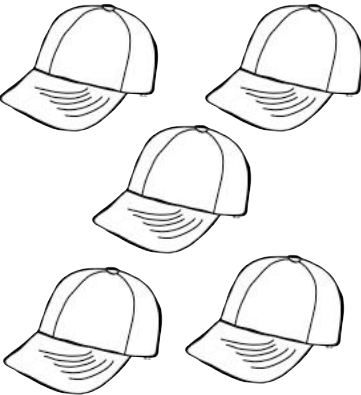
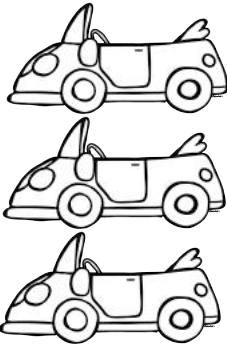
Count the objects. Circle the correct answer.



Name \_\_\_\_\_

Count the objects. Circle the correct answer.

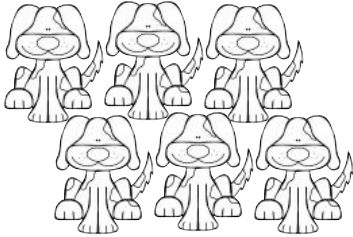

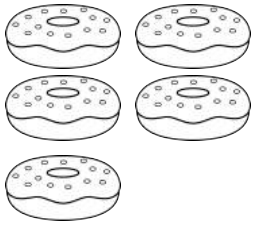
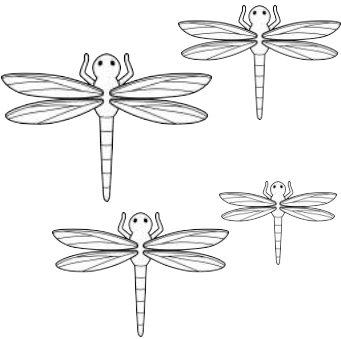
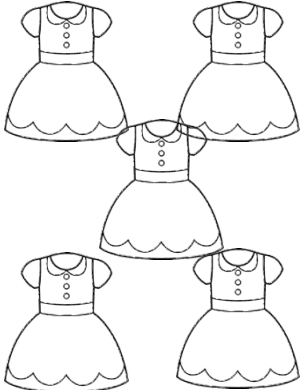
 <p>3 4 5 6 7</p>	 <p>3 4 5 6 7</p>	 <p>3 4 5 6 7</p>
 <p>3 4 5 6 7</p>	 <p>3 4 5 6 7</p>	 <p>3 4 5 6 7</p>

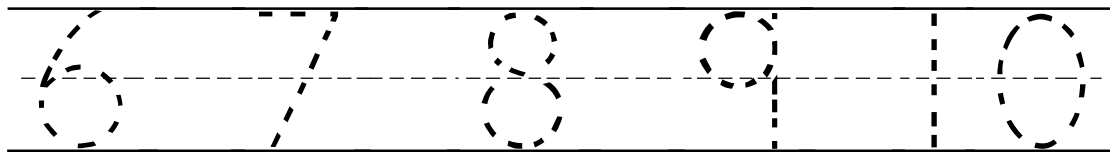
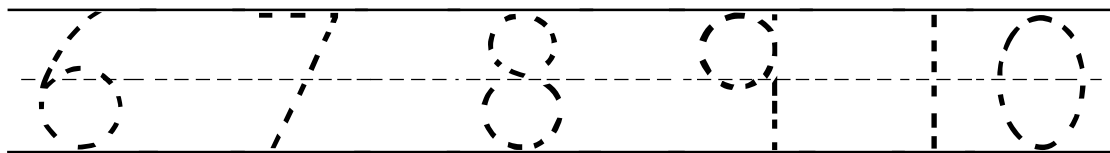
Trace the numbers. Write them below.

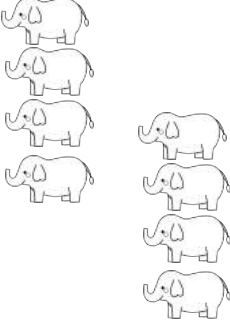
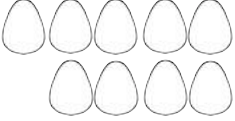

Name \_\_\_\_\_

Count the objects. Circle the correct answer.

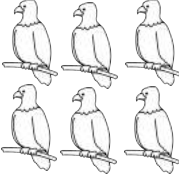
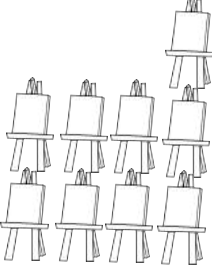
	<p>6 7 8 9 10</p>		<p>6 7 8 9 10</p>		<p>6 7 8 9 10</p>
	<p>6 7 8 9 10</p>		<p>6 7 8 9 10</p>		<p>6 7 8 9 10</p>

Trace the numbers. Write them below.

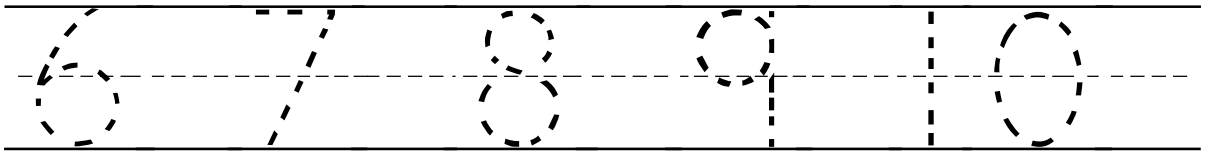
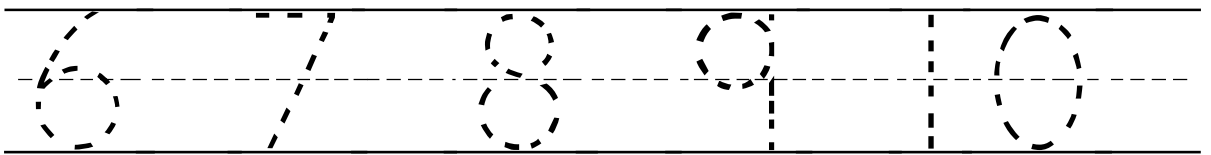

Name \_\_\_\_\_

Count the objects. Circle the correct answer.

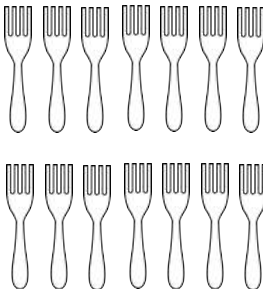
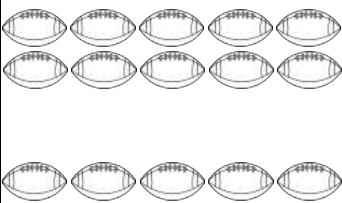
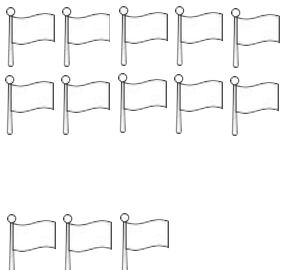
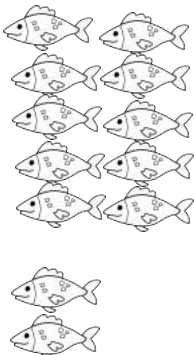
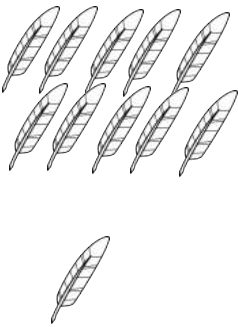
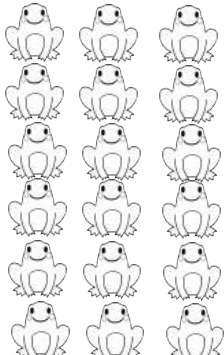
		
11	11	11
12	12	12
13	13	13
14	14	14
15	15	15
		
11	11	11
12	12	12
13	13	13
14	14	14
15	15	15

Trace the numbers. Write them below.

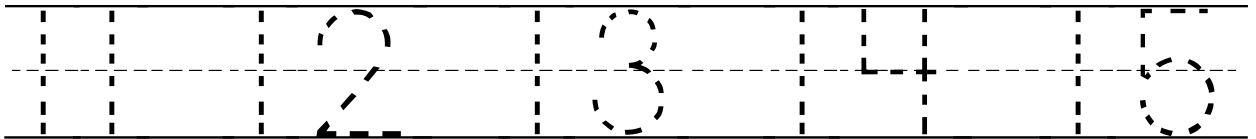
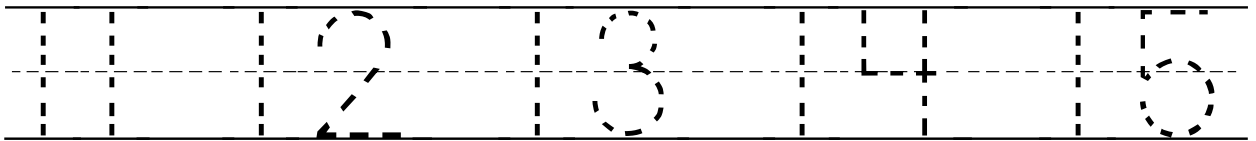

Name \_\_\_\_\_

Count the objects. Circle the correct answer.



13

14



15

16



17

18

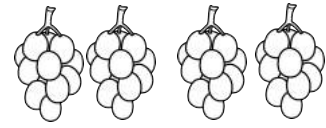

13

14

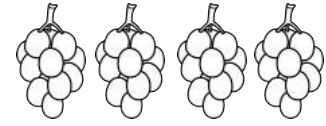

15

16

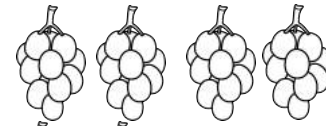

17

18



13

14



15

16



17

18



13

14

15

16

17

18



13



14



15



16



17



18



13



14



15



16



17



18



13

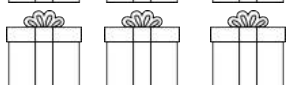

14

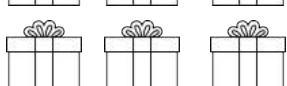

15

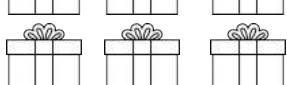

16

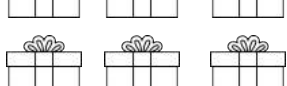

17

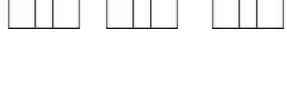

18



13



14



15



16



17

18



13



14

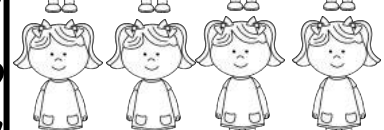

15



16





17

18

Name \_\_\_\_\_

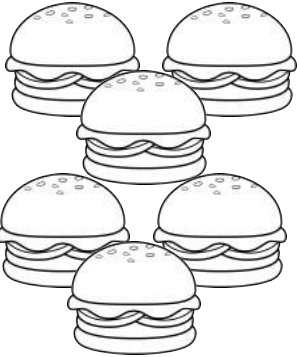
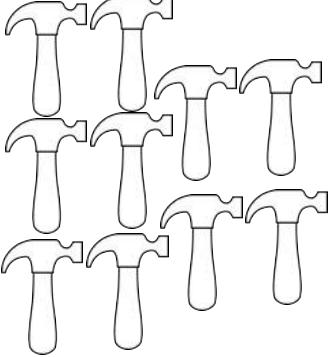
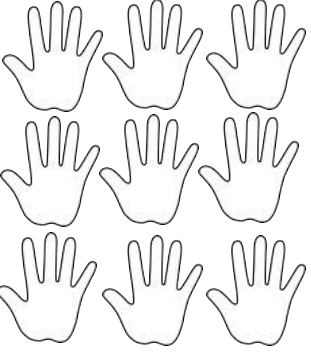
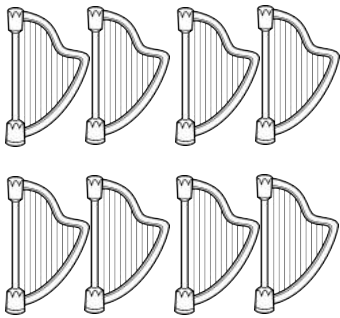
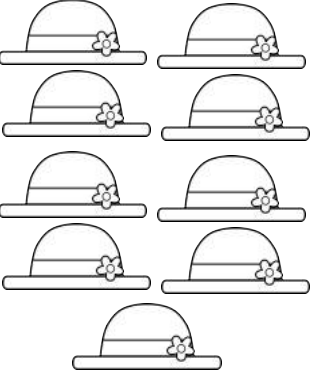
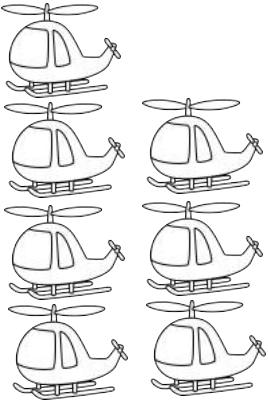
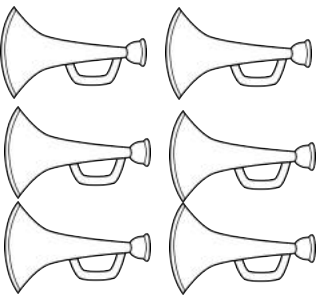
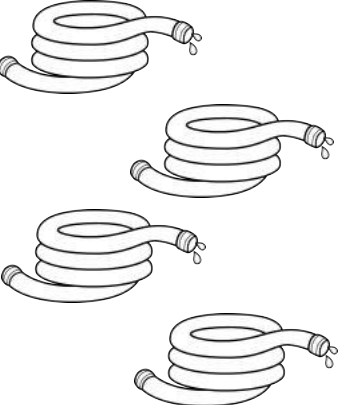
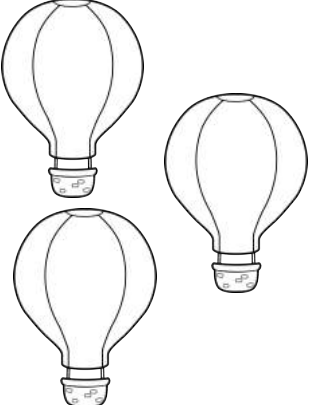
Count the objects. Circle the correct answer.

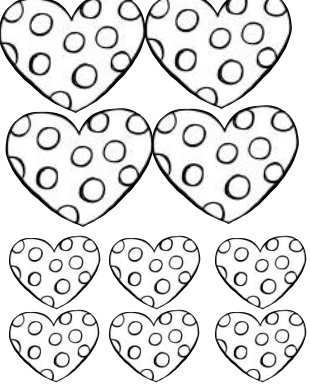
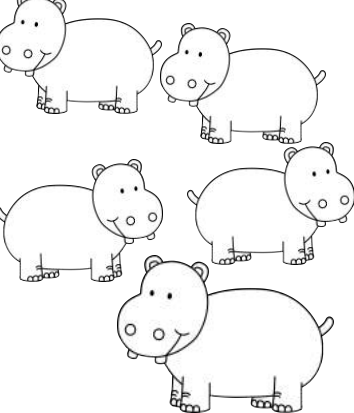
	<p>6 7 8 9 10</p>		<p>6 7 8 9 10</p>		<p>6 7 8 9 10</p>
	<p>6 7 8 9 10</p>		<p>6 7 8 9 10</p>		<p>6 7 8 9 10</p>
	<p>6 7 8 9 10</p>		<p>3 4 5 6 7</p>		<p>3 4 5 6 7</p>
	<p>3 4 5 6 7</p>		<p>6 7 8 9 10</p>		<p>3 4 5 6 7</p>

Click to see more number sense resources for your classroom use.

**NUMBER  
SENSE 1 TO 10**

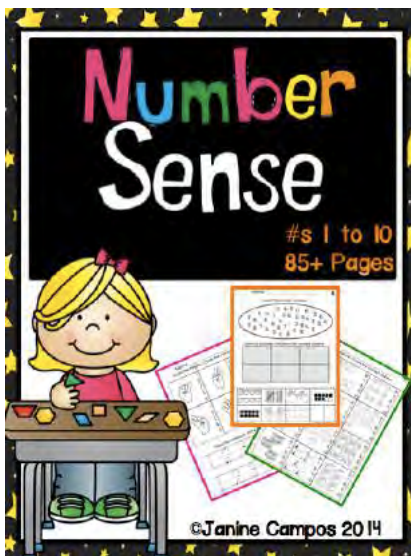

**NUMBER  
SENSE 11 TO 20**

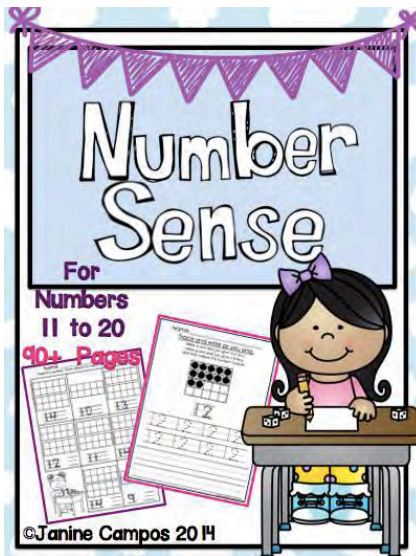

**NUMBER  
SENSE 21 TO 30**

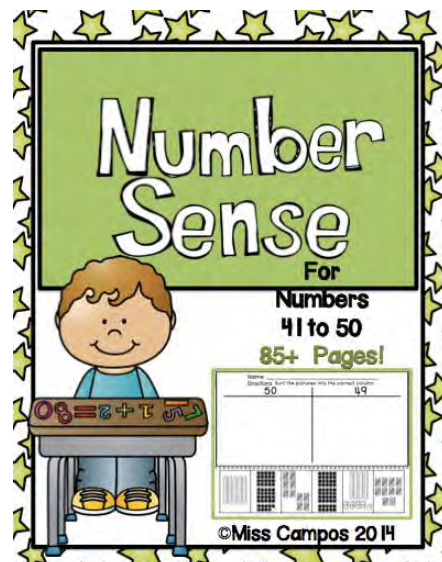
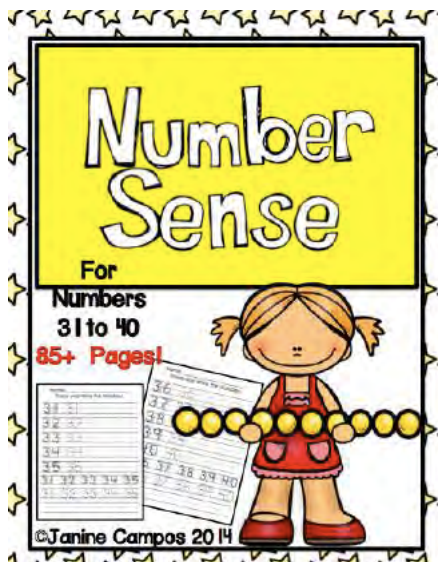
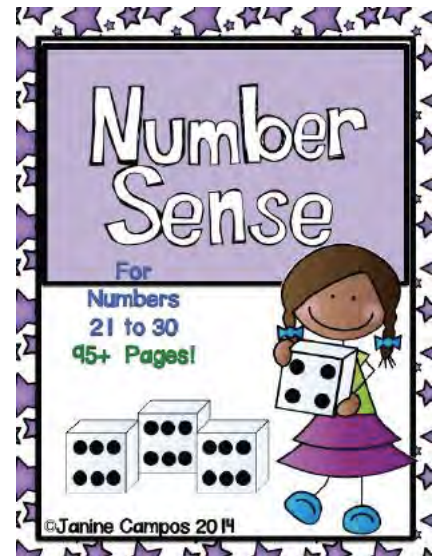

**NUMBER  
SENSE 31 TO 40**

**NUMBER  
SENSE 41 TO 50**



Thank you for your download. Please consider returning to my digital store to give a rating on this product and write a feedback comment. You can link to my digital store through my blog on [www.misscampos.com](http://www.misscampos.com)

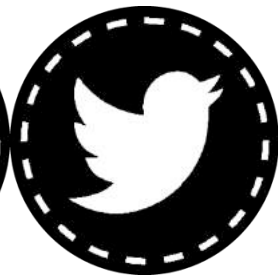

**Credits:**



Redistributing, editing, selling, posting this product on the internet, or any part thereof, is strictly prohibited without first gaining permission of the author, Janine Campos. Violations are subject to penalties of the Digital Millennium Copyright Act. Contact Miss Campos through email

at: [misscamposclass@gmail.com](mailto:misscamposclass@gmail.com)